

W-15

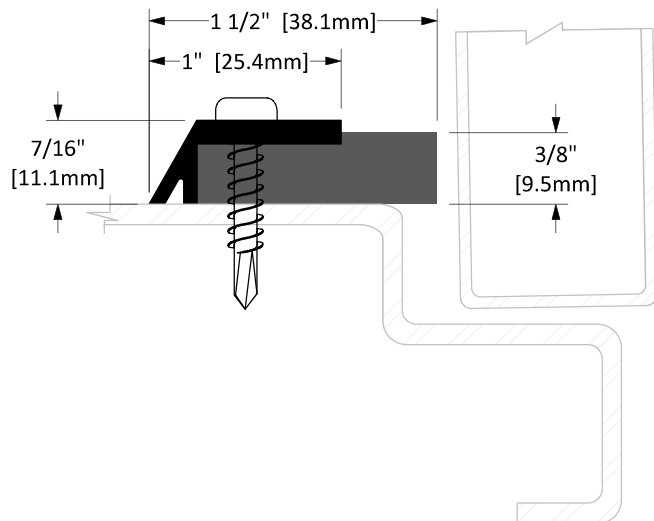

STD Finish Options
Clear Anodized

Standard Screw Options
Screw Type: **C**
#8 X 1" Stainless Steel Pan Head,
Robertson Drive, Tek Screws

Optional Screw Type: **D**
#8 X 1" Stainless Steel Pan Head,
Tamper-Resistant Torx Drive, Tek Screws

Operation	Weatherstrip
Features	<ul style="list-style-type: none"> Clear Anodized Extruded Aluminum with Closed Cell Neoprene
Application	<ul style="list-style-type: none"> Ideal for Residential, Commercial & Industrial

Customer Name: _____ Job No./Name: _____ Date: _____ Provided By: _____

Notes: