

W-13S-SS



Intertek

Finish Options

STD

18 GA. 304 Stainless Steel 2B

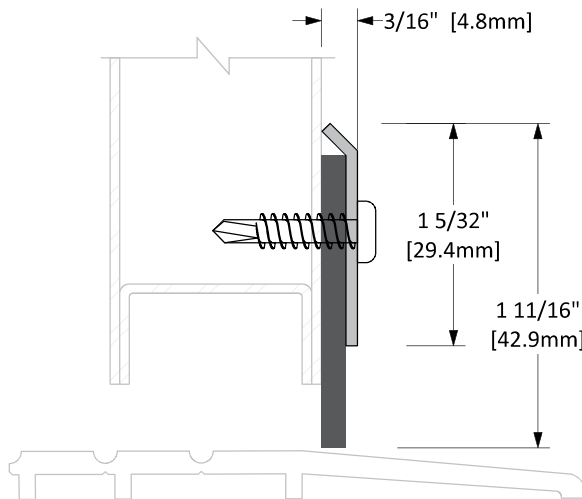

Screw Options

STANDARD
OPTIONAL

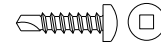

SCREW TYPE: **A**
 #8 X 3/4" STAINLESS STEEL PAN
 HEAD, ROBERTSON DRIVE, TEK
 SCREWS



SCREW TYPE: **B**
 #8 X 3/4" STAINLESS STEEL PAN
 HEAD, TAMPER-RESISTANT TORX
 DRIVE, TEK SCREWS

Operation	Door Sweep
Features	<ul style="list-style-type: none"> Stainless Steel with Black Solid Neoprene
Application	<ul style="list-style-type: none"> Ideal for Residential, Commercial & Industrial

Part No.:

Part Description:

Customer Name:

Job No./Name:

Date:

Provided By:

Notes: