

C-206-4 HANGER FOR C-204 TRACK INSTRUCTION SHEET

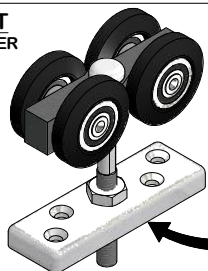

PARTS LIST

C-206-4 HANGER ASSEMBLED (2 PER DOOR)



#10 X 1-3/4" FLATHEAD SCREWS (4 PER HANGER)



EXTRUDED ALUMINUM TRACK



SQUARE NUT INCLUDED IN ASSEMBLY



SPECIFICATIONS:

-LOAD CAPACITY: 225 LBS PER DOOR.

-DESIGNED FOR TOP MOUNTING.

-HEAVY-DUTY PRECISION BALL BEARING STEEL WHEELS.

-LOCK NUTS HOLD VERTICAL ADJUSTMENT.

-FOR BY-PASSING, BI-PARTING, POCKET, AND SURFACE MOUNT/BARN STYLE APPLICATIONS.

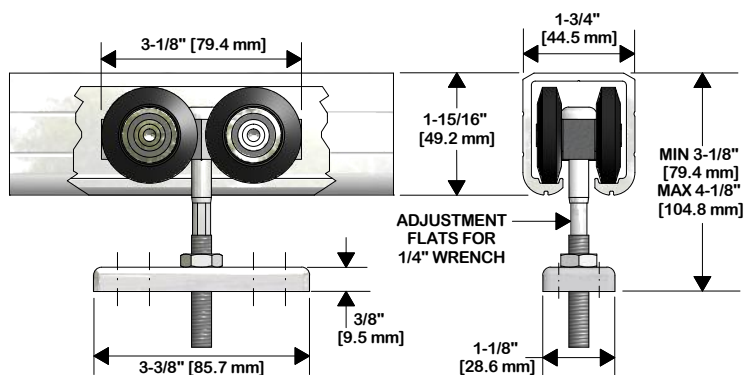

STEP 1
DETERMINE DOOR SIZE/HEADER HEIGHT BASED ON DIMENSIONS SHOWN IN DETAIL VIEWS AND CLEARANCE REQUIRED BELOW DOOR.

STEP 2

A) LOCATE CENTER CLEARANCE HOLE FOR HANGER STUD 4-1/2" FROM EACH EDGE OF DOOR. DRILL WITH 3/8"Ø BIT AT LEAST 1-1/2" DEEP. IF USING KNC CAS-2 DOOR STOP, LOCATE CLEARANCE HOLE 5-1/2" FROM EDGE OF DOOR.

B) CENTER TOP/SIDE PLATE OVER HOLE, MARK SCREW HOLE LOCATIONS AND PRE-DRILL WITH 1/8"Ø BIT AT LEAST 1-1/2" DEEP.

STEP 3

PREPARE DOOR FOR INSTALLATION OF OPTIONAL PRODUCTS IF PURCHASED SUCH AS GUIDE CHANNELS, CUP PULLS, DOOR LOCKS, ETC. INDIVIDUAL INSTRUCTIONS ARE PROVIDED WITH THE RESPECTIVE PRODUCT.

STEP 4

MOUNT HANGER ASSEMBLY ON DOOR AND SECURE TOP PLATE WITH #10 X 1-3/4" FLATHEAD SCREWS(4).

STEP 5

PLACE DOOR AND HANGERS INTO C-204 TRACK AND SECURE TO HEADER.

STEP 6

ADJUST DOOR HEIGHT AND PLUMB USING 1/4" WRENCH ON BOLT. LOCK ADJUSTMENT BY TIGHTENING HEX NUT AGAINST TOP PLATE WITH 1/2" WRENCH.

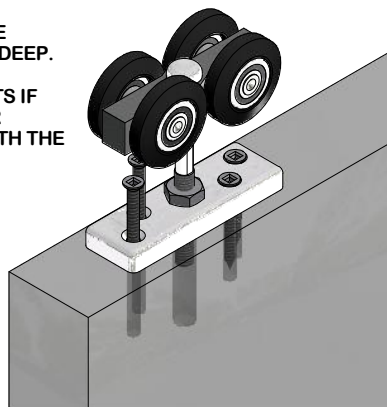
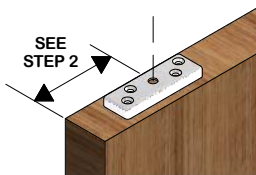

C-206-4 HANGER FOR C-204 TRACK INSTRUCTION SHEET



PARTS LIST

C-206-4 HANGER ASSEMBLED (2 PER DOOR)

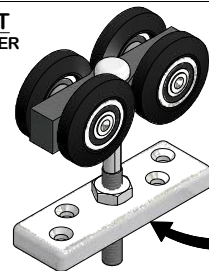

#10 X 1-3/4" FLATHEAD SCREWS (4 PER HANGER)



EXTRUDED ALUMINUM TRACK



SQUARE NUT INCLUDED IN ASSEMBLY



SPECIFICATIONS:

-LOAD CAPACITY: 225 LBS PER DOOR.

-DESIGNED FOR TOP MOUNTING.

-HEAVY-DUTY PRECISION BALL BEARING STEEL WHEELS.

-LOCK NUTS HOLD VERTICAL ADJUSTMENT.

-FOR BY-PASSING, BI-PARTING, POCKET, AND SURFACE MOUNT/BARN STYLE APPLICATIONS.

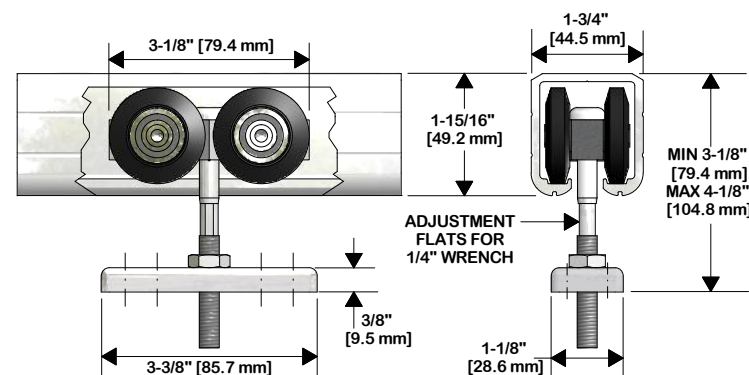

STEP 1
DETERMINE DOOR SIZE/HEADER HEIGHT BASED ON DIMENSIONS SHOWN IN DETAIL VIEWS AND CLEARANCE REQUIRED BELOW DOOR.

STEP 2

A) LOCATE CENTER CLEARANCE HOLE FOR HANGER STUD 4-1/2" FROM EACH EDGE OF DOOR. DRILL WITH 3/8"Ø BIT AT LEAST 1-1/2" DEEP. IF USING KNC CAS-2 DOOR STOP, LOCATE CLEARANCE HOLE 5-1/2" FROM EDGE OF DOOR.

B) CENTER TOP/SIDE PLATE OVER HOLE, MARK SCREW HOLE LOCATIONS AND PRE-DRILL WITH 1/8"Ø BIT AT LEAST 1-1/2" DEEP.

STEP 3

PREPARE DOOR FOR INSTALLATION OF OPTIONAL PRODUCTS IF PURCHASED SUCH AS GUIDE CHANNELS, CUP PULLS, DOOR LOCKS, ETC. INDIVIDUAL INSTRUCTIONS ARE PROVIDED WITH THE RESPECTIVE PRODUCT.

STEP 4

MOUNT HANGER ASSEMBLY ON DOOR AND SECURE TOP PLATE WITH #10 X 1-3/4" FLATHEAD SCREWS(4).

STEP 5

PLACE DOOR AND HANGERS INTO C-204 TRACK AND SECURE TO HEADER.

STEP 6

ADJUST DOOR HEIGHT AND PLUMB USING 1/4" WRENCH ON BOLT. LOCK ADJUSTMENT BY TIGHTENING HEX NUT AGAINST TOP PLATE WITH 1/2" WRENCH.

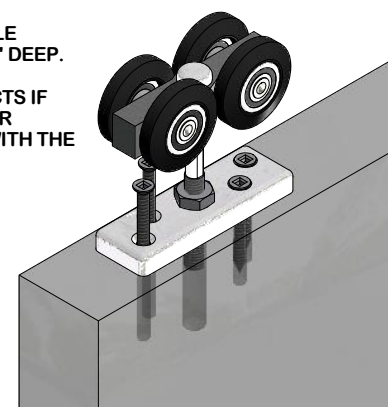
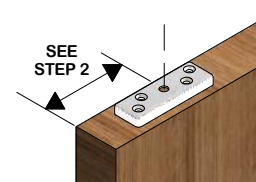

K.N. CROWDER MFG. INC.
1220 BURLOAK DRIVE
BURLINGTON, ONTARIO, CANADA, L7L 6B3
TELEPHONE: 905-315-9788 - FAX: 905-315-8090
TOLL FREE FAX: 1-800-567-0123

K.N. CROWDER INC.
210 EIGHTH STREET SOUTH
LEWISTON, NEW YORK, U.S.A. 14092
TELEPHONE: 1-716-754-8247
TOLL FREE FAX: 1-800-567-0123

WEBSITE: www.kncrowder.com -- E-MAIL: customerservice@kncrowder.com



K.N. CROWDER MFG. INC.
1220 BURLOAK DRIVE
BURLINGTON, ONTARIO, CANADA, L7L 6B3
TELEPHONE: 905-315-9788 - FAX: 905-315-8090
TOLL FREE FAX: 1-800-567-0123

K.N. CROWDER INC.
210 EIGHTH STREET SOUTH
LEWISTON, NEW YORK, U.S.A. 14092
TELEPHONE: 1-716-754-8247
TOLL FREE FAX: 1-800-567-0123

WEBSITE: www.kncrowder.com -- E-MAIL: customerservice@kncrowder.com