

Installation Instructions

Step #1:

Once jamb is prepped for strike, loosely fasten Back Plate to jamb using two (2) #8-32 x 1-1/4" Pancake Combo Screws.

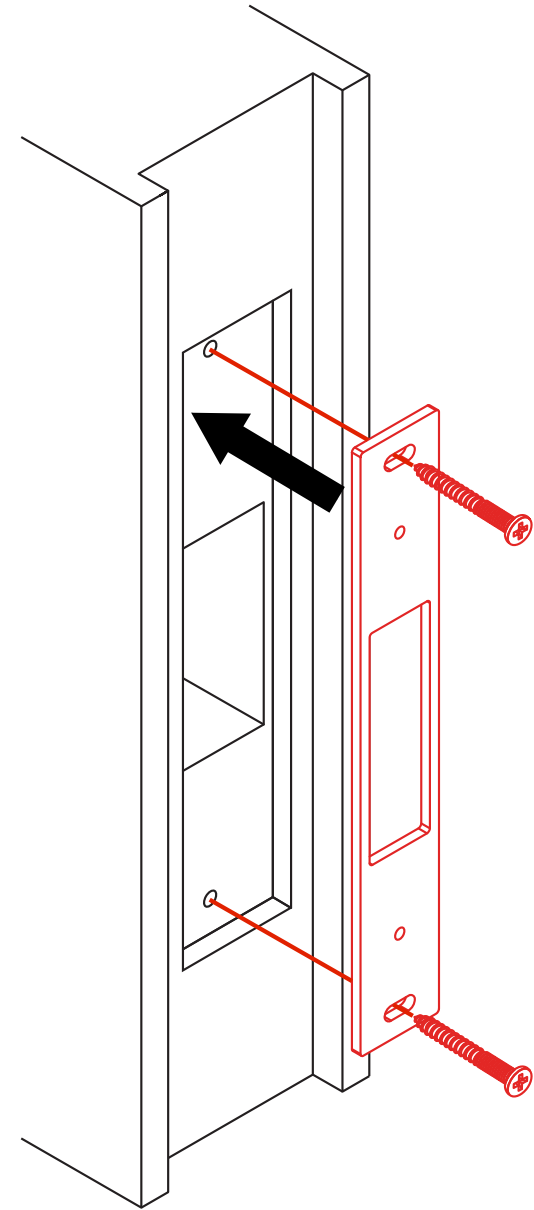

Step #2:

Insert Dust Box.

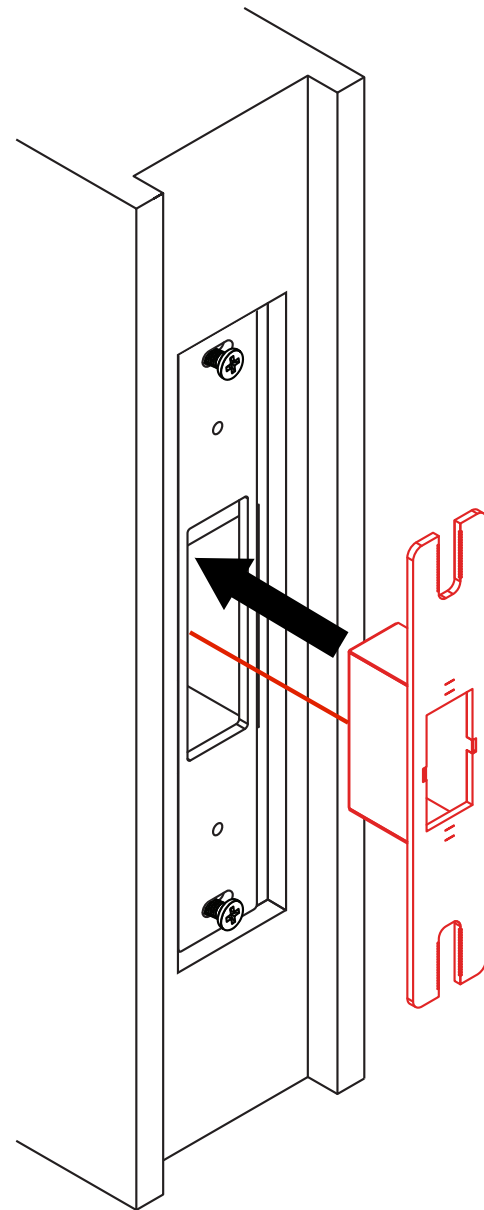

Step #3:

Loosely fasten Test Plate using two (2) M4 x 6 mm Phillips Head Machine Screws through top and bottom holes.

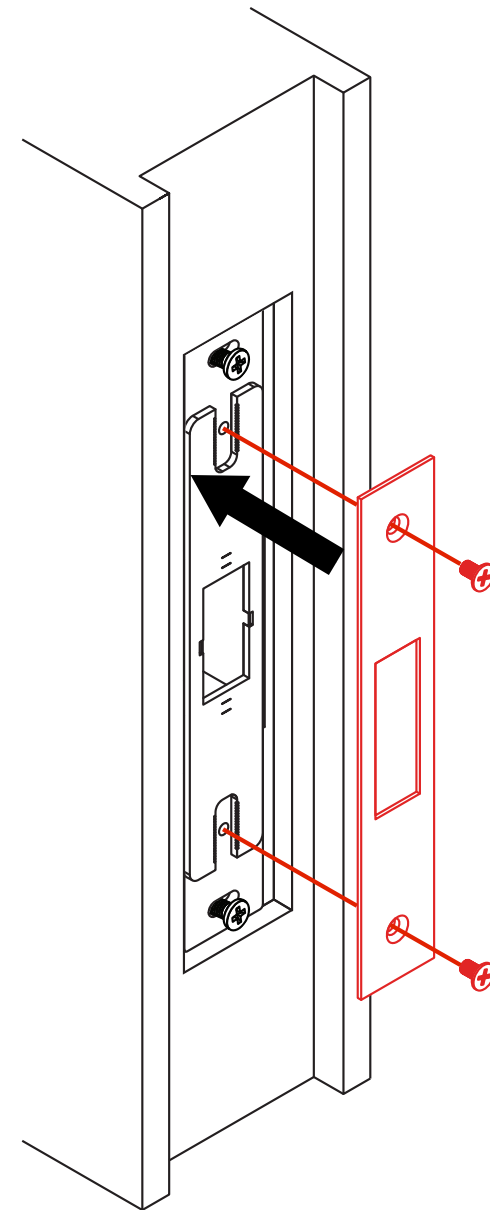

Step #4:

Make minor adjustments accordingly. Back Plate shifts horizontally ①, and Dust Box shifts vertically ②.

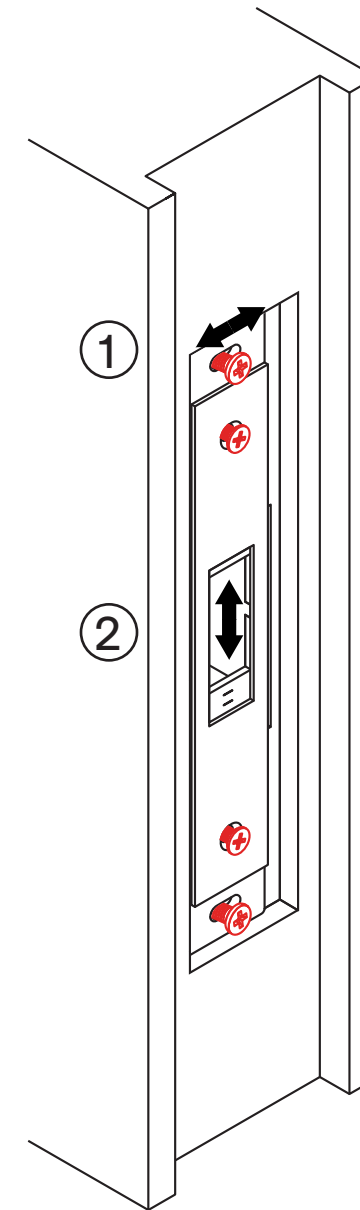

Step #5:

Once position is finalized, tightly fasten screws through Back Plate and unfasten Test Plate screws to remove Test Plate.

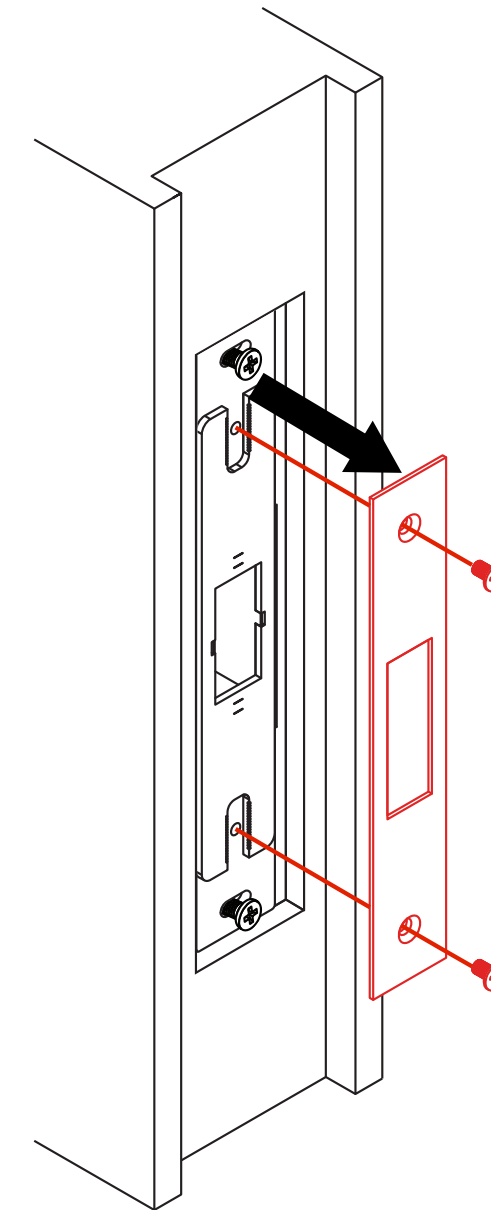

Step #6:

Fasten Face Plate using two (2) M4 x 6 mm Screws. Adjust Dust Box and tightly fasten.

