

C-90L-CC Security Lockset

Installation Instructions



Specifications

Case: Heavy gauge wrought

Armor Front: Brass, bronze, stainless

Dead Bolt: 1/2 in [12.7 mm] thick x 1 7/32 in [31 mm] high x 1 in [25.4 mm] throw

Pull: 1/2 in [12.7 mm] thick x 2 in [50.8 mm] high x 1 1/4 in [31.8 mm] throw

Thumb Turn Hub: 3/16 in [4.8 mm] on the diamond

Cam: See details on right

Door Thickness: 1 3/4 in [44.5 mm] to 2 1/4 in [57.2 mm]

Cam Required: B520-233

Dimensions

W = 1.000 in [25.4 mm]

X = 0.232 in [5.9 mm]

Y = 0.729 in [18.5 mm]

Z = 0.694 in [17.6 mm]

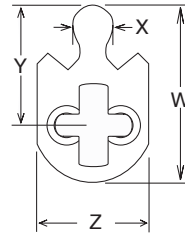

Not to scale

Included Components

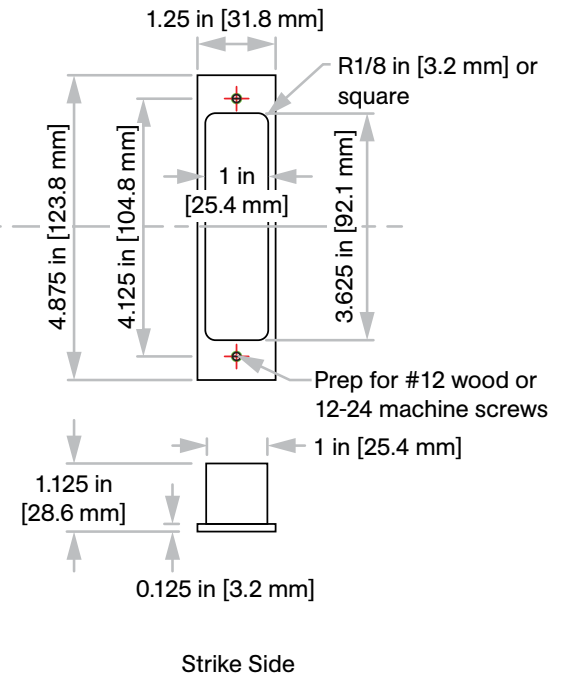
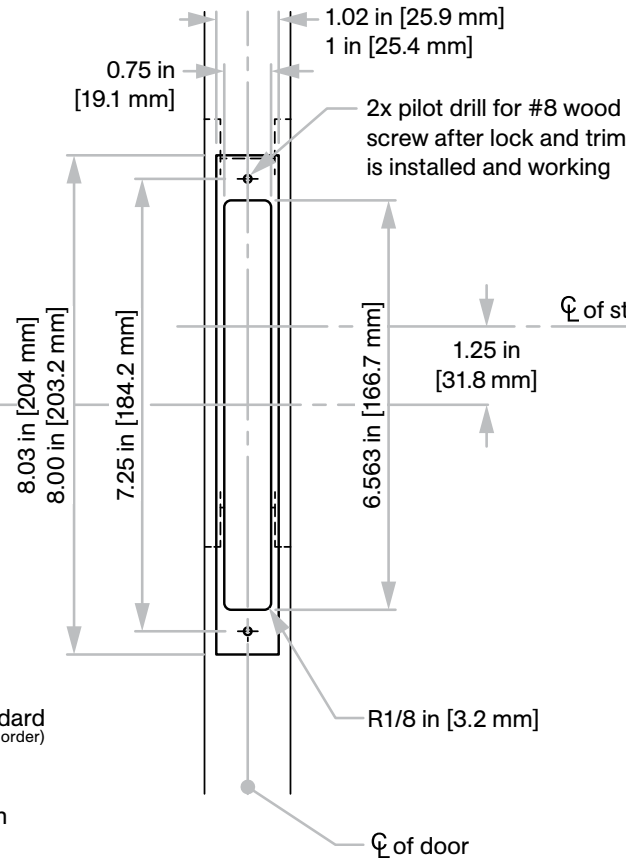
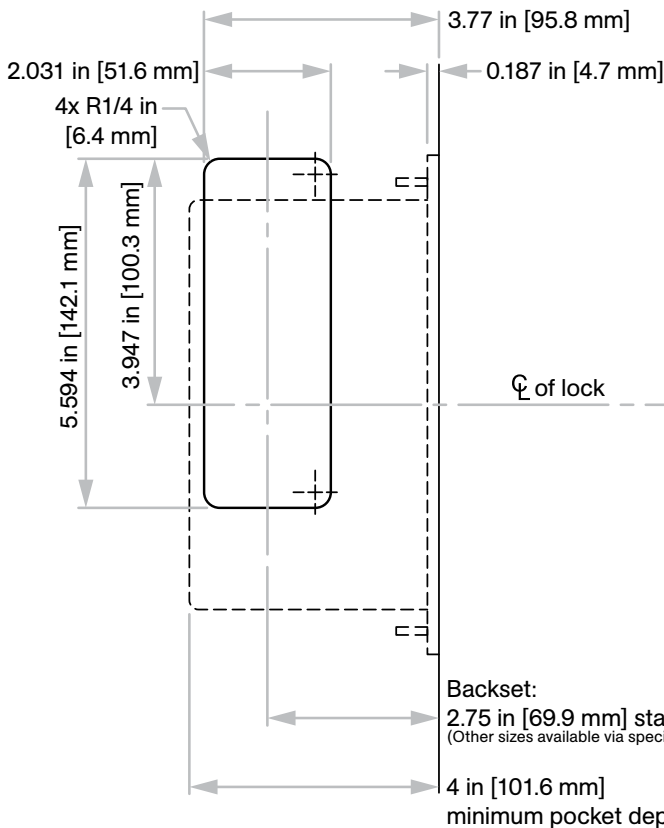
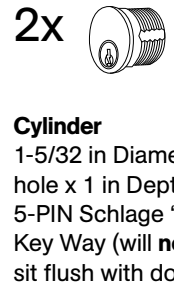
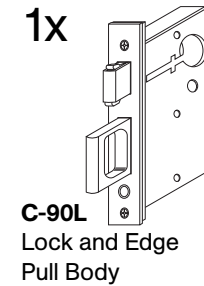

Note: When using two 1 in [25.4 mm] depth cylinders, they will not sit flush with flush pulls on a 1 3/4 in [44.5 mm] door. Therefore, cylinders will protrude past face of door.