

C-993 HANGER FOR C-104 OR C-108 TRACK

INSTRUCTION SHEET

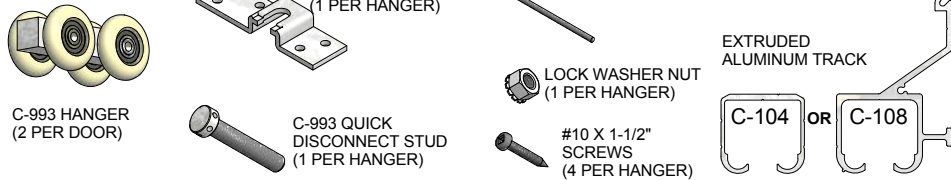

PARTS LIST



SPECIFICATIONS:
-LOAD CAPACITY:
250 LBS PER DOOR.

-HEAVY DUTY 3/8" DIAMETER BOLT

-HEAVY-DUTY PRECISION BALL BEARING WHEELS WITH NYLON TIRE.

-QUICK RELEASE HANGER ASSEMBLY.

-FOR BY-PASSING, BI-PARTING, POCKET, AND SURFACE MOUNT/BARN STYLE APPLICATIONS.

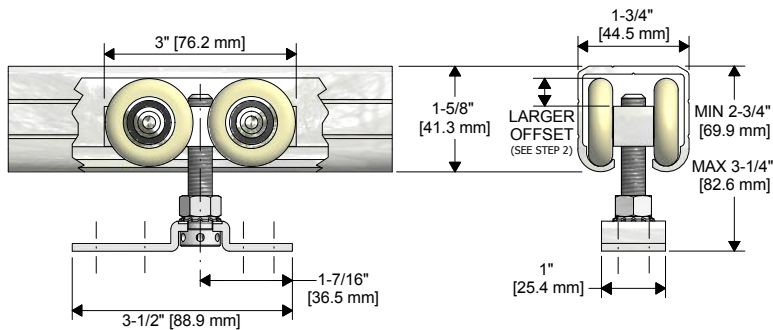

STEP 1
DETERMINE DOOR SIZE/HEADER HEIGHT BASED ON DIMENSIONS SHOWN IN DETAIL VIEWS AND CLEARANCE REQUIRED BELOW DOOR.

STEP 2
1) THREAD LOCK WASHER NUT ONTO C-993 QUICK DISCONNECT STUD WITH LOCK WASHER FACING BOLT HEAD. 2) THREAD HANGER STUD INTO C-993 HANGER (SEE DIMENSION DETAILS FOR AXLE OFFSET NOTE). INSERT C-993 HANGERS (WITH BOLT AND NUT) INTO TRACK AND SECURE TRACK TO HEADER.

STEP 3
LOCATE CENTER OF C-993 TOP PLATE 4-1/2" FROM EACH EDGE OF DOOR. MARK SCREW HOLE LOCATIONS AND PRE-DRILL 1/8" HOLES AT LEAST 1-1/2" DEEP. **IF USING KNC CAS-2 DOOR STOP**, LOCATE CENTER OF TOP PLATE 5-1/2" FROM EDGE OF DOOR. MOUNT TOP PLATE ON DOOR AND SECURE WITH #10 X 1-1/2" SCREWS (4 PER TOP PLATE).

STEP 4
PREPARE DOOR FOR INSTALLATION OF OPTIONAL PRODUCTS IF PURCHASED SUCH AS GUIDE CHANNELS, CUP PULLS, DOOR LOCKS, ETC. INDIVIDUAL INSTRUCTIONS ARE PROVIDED WITH THE RESPECTIVE PRODUCT.

STEP 5
PLACE DOOR UNDER HANGERS AND LIFT ONTO BOLTS. SCREW NUTS DOWN ON TOP OF TOP PLATE BUT DO NOT TIGHTEN. ADJUST DOOR HEIGHT AND PLUMB WITH ADJUSTMENT ROD ON BOLT HEAD (SMALL HOLES IN HEAD). LOCK ADJUSTMENT BY TIGHTENING HEX LOCK WASHER NUT AGAINST TOP PLATE WHILE USING THE ADJUSTMENT ROD TO PREVENT BOLT FROM TURNING.

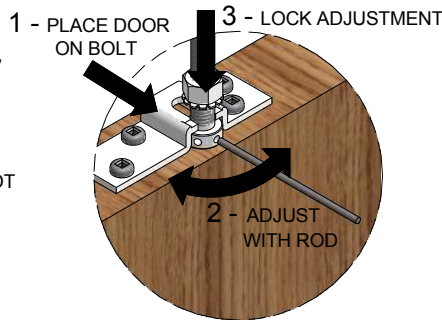
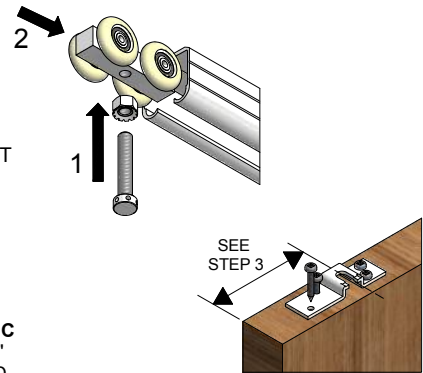

K.N. CROWDER MFG. INC.
1220 BURL OAK DRIVE
BURLINGTON, ONTARIO, CANADA, L7L 6B3
TELEPHONE: 905-315-9788 - FAX: 905-315-8090
TOLL FREE FAX: 1-800-567-0123

WEBSITE: www.kncrowder.com --- E-MAIL: customerservice@kncrowder.com

K.N. CROWDER INC.
210 EIGHTH STREET SOUTH
LEWISTON, NEW YORK, U.S.A. 14092
TELEPHONE: 1-716-754-8247
TOLL FREE FAX: 1-800-567-0123

C-993 HANGER FOR C-104 OR C-108 TRACK

INSTRUCTION SHEET



PARTS LIST

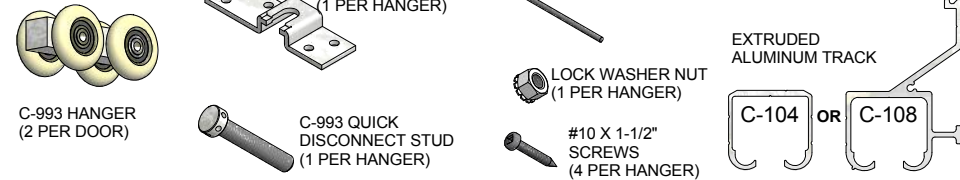

SPECIFICATIONS:
-LOAD CAPACITY:
250 LBS PER DOOR.

-HEAVY DUTY 3/8" DIAMETER BOLT

-HEAVY-DUTY PRECISION BALL BEARING WHEELS WITH NYLON TIRE.

-QUICK RELEASE HANGER ASSEMBLY.

-FOR BY-PASSING, BI-PARTING, POCKET, AND SURFACE MOUNT/BARN STYLE APPLICATIONS.

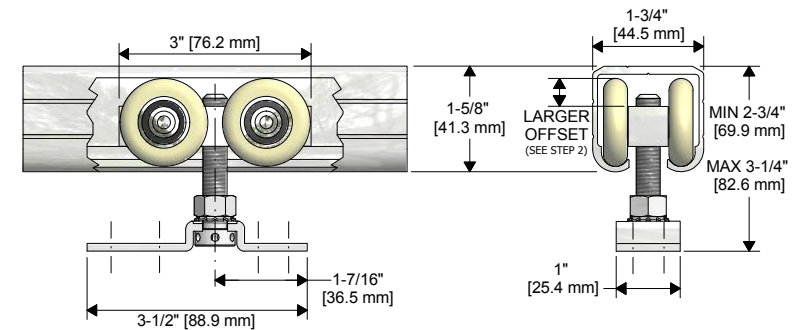

STEP 1
DETERMINE DOOR SIZE/HEADER HEIGHT BASED ON DIMENSIONS SHOWN IN DETAIL VIEWS AND CLEARANCE REQUIRED BELOW DOOR.

STEP 2
1) THREAD LOCK WASHER NUT ONTO C-993 QUICK DISCONNECT STUD WITH LOCK WASHER FACING BOLT HEAD. 2) THREAD HANGER STUD INTO C-993 HANGER (SEE DIMENSION DETAILS FOR AXLE OFFSET NOTE). INSERT C-993 HANGERS (WITH BOLT AND NUT) INTO TRACK AND SECURE TRACK TO HEADER.

STEP 3
LOCATE CENTER OF C-993 TOP PLATE 4-1/2" FROM EACH EDGE OF DOOR. MARK SCREW HOLE LOCATIONS AND PRE-DRILL 1/8" HOLES AT LEAST 1-1/2" DEEP. **IF USING KNC CAS-2 DOOR STOP**, LOCATE CENTER OF TOP PLATE 5-1/2" FROM EDGE OF DOOR. MOUNT TOP PLATE ON DOOR AND SECURE WITH #10 X 1-1/2" SCREWS (4 PER TOP PLATE).

STEP 4
PREPARE DOOR FOR INSTALLATION OF OPTIONAL PRODUCTS IF PURCHASED SUCH AS GUIDE CHANNELS, CUP PULLS, DOOR LOCKS, ETC. INDIVIDUAL INSTRUCTIONS ARE PROVIDED WITH THE RESPECTIVE PRODUCT.

STEP 5
PLACE DOOR UNDER HANGERS AND LIFT ONTO BOLTS. SCREW NUTS DOWN ON TOP OF TOP PLATE BUT DO NOT TIGHTEN. ADJUST DOOR HEIGHT AND PLUMB WITH ADJUSTMENT ROD ON BOLT HEAD (SMALL HOLES IN HEAD). LOCK ADJUSTMENT BY TIGHTENING HEX LOCK WASHER NUT AGAINST TOP PLATE WHILE USING THE ADJUSTMENT ROD TO PREVENT BOLT FROM TURNING.

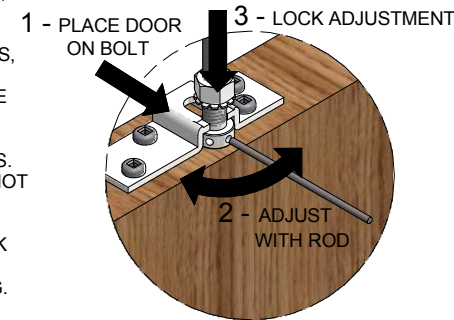
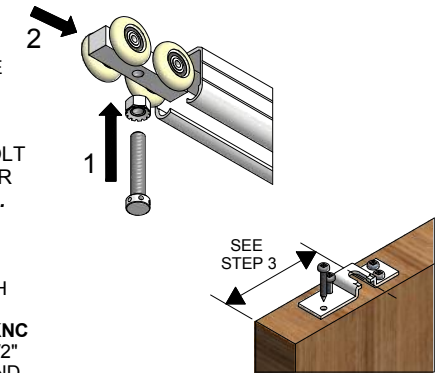

K.N. CROWDER MFG. INC.
1220 BURL OAK DRIVE
BURLINGTON, ONTARIO, CANADA, L7L 6B3
TELEPHONE: 905-315-9788 - FAX: 905-315-8090
TOLL FREE FAX: 1-800-567-0123

WEBSITE: www.kncrowder.com --- E-MAIL: customerservice@kncrowder.com

K.N. CROWDER INC.
210 EIGHTH STREET SOUTH
LEWISTON, NEW YORK, U.S.A. 14092
TELEPHONE: 1-716-754-8247
TOLL FREE FAX: 1-800-567-0123

