

CAS-1 DOOR STOP INSTRUCTION SHEET

PARTS LIST

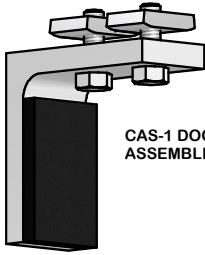

CAS-1 DOOR STOP ASSEMBLED

TRACK COMPATIBILITY

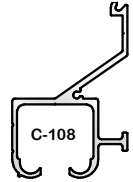
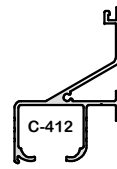

CAS-1 DOOR STOP IS USED FOR STOPPING LARGE DOORS AT THE REQUIRED LOCATION.

INSTRUCTIONS:

CAS-1 CAN BE INSTALLED PRIOR TO MOUNTING THE TRACK ON THE HEADER OR AFTER THE TRACK IS INSTALLED. IT IS RECOMMENDED TO INSTALL PRIOR TO SECURING TRACK TO HEADER.

STEP 1

INSTALL CAS-1 DOOR STOP BY SLIDING IT ON TO THE TRACK FROM THE END WITH THE SQUARE NUTS INSIDE THE TRACK. SEE ILLUSTRATION FOR MORE DETAILS.

STEP 2

INSTALL DOOR AND OTHER REQUIRED PRODUCTS. DOOR HANGERS MUST BE AT LEAST 3" FROM THE EDGE OF THE DOOR TO AVOID OBSTRUCTION WITH THE CAS-1.

STEP 3

PLACE DOOR IN CLOSED OR THE REQUIRED STOPPING LOCATION. SLIDE CAS-1 UP AGAINST THE DOOR EDGE. USING A 1/2" WRENCH TIGHTEN THE BOLTS TO CLAMP THE SQUARE NUTS AGAINST THE TRACK.

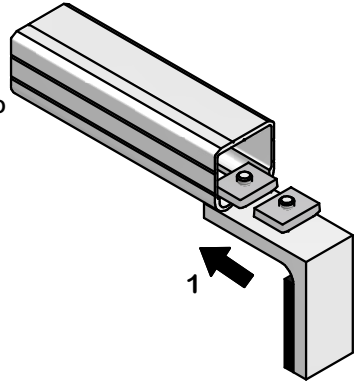

(CAS-1 IS SHOWN WITH C-104 TRACK WITH C-994 HANGER)

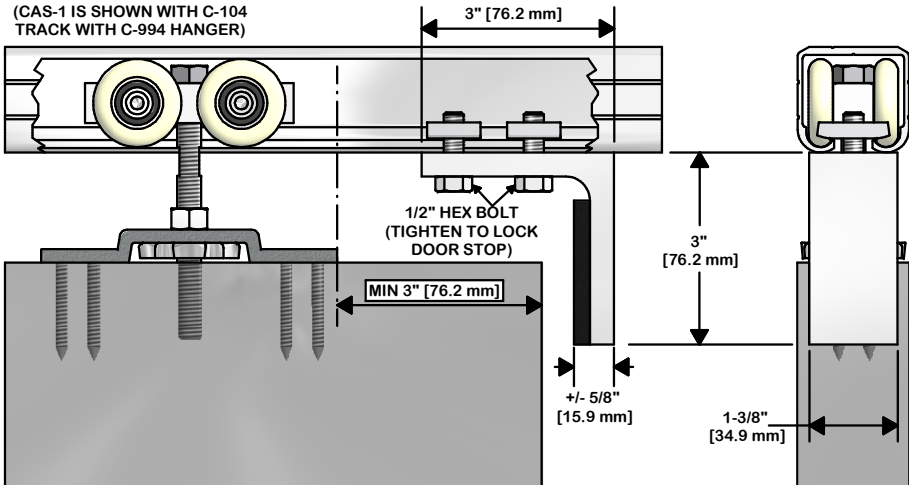

K.N. CROWDER MFG. INC.
1220 BURLOAK DRIVE
BURLINGTON, ONTARIO, CANADA, L7L 6B3
TELEPHONE: 905-315-9788 - FAX: 905-315-8090
TOLL FREE FAX: 1-800-567-0123

K.N. CROWDER INC.
210 EIGHTH STREET SOUTH
LEWISTON, NEW YORK, U.S.A. 14092
TELEPHONE: 1-716-754-8247
TOLL FREE FAX: 1-800-567-0123

WEBSITE: www.kncrowder.com -- E-MAIL: customerservice@kncrowder.com