

CCD-410

Installation Instructions

Zero Clearance Catch 'N' Close System

- Prevents bouncing and slamming of sliding doors
- Can be installed on both opening and closing ends of doors as narrow as 18 in [457 mm]
- Cycle tested up to 150,000 times
- For up to 150 lbs. [68 kg] using CC-410 with CC-1

Parts List

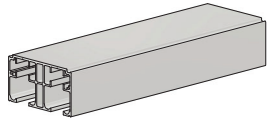

CC-500 Double Track x length (1)
Length = 2 x door width, example:
36 in [914 mm] door = 72 in [1829 mm] track

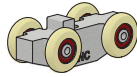

CC-400 Hanger Body (4)
c/w wheels

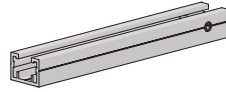

CC-410-UH 'U'-Housing (4)

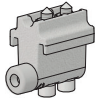

CC-100 Catch 'N' Close In-Track Stops (4)



CP Adjustment Wrench (1)



CC-410-LN Lock Nut (4)



CC-410-CB 'C'-Bar (4)



CC-410-EC End Cap (4)



CC-410 Hex Head Bolt x 1-1/4" (4)

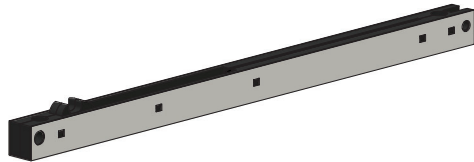

Catch 'N' Close Device (4)
See details in instruction steps



#10 x 1-1/4" Flat Head Machine Screws (4)
[FT3]



#10 x 1-1/4" Pan Head Screws (16)
[FT4]



#10 x 1-1/2" Self-Drilling Screws (8)
[FT5]

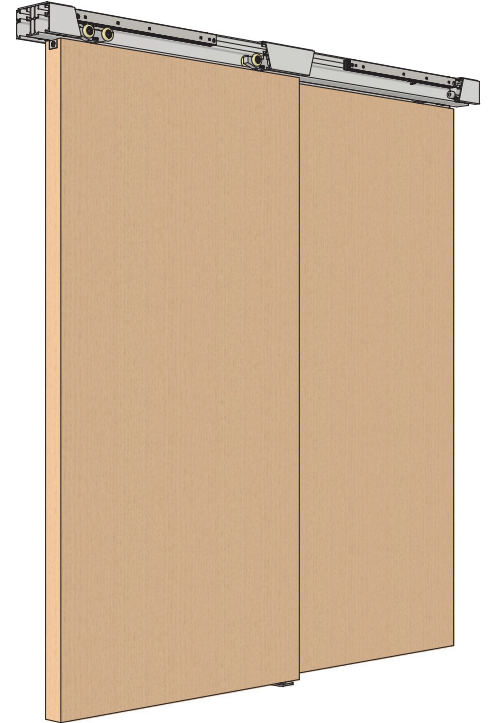

Complete CCD-410-W kit illustrated. Cut-outs in track to expose components.

Optional Add-on Products

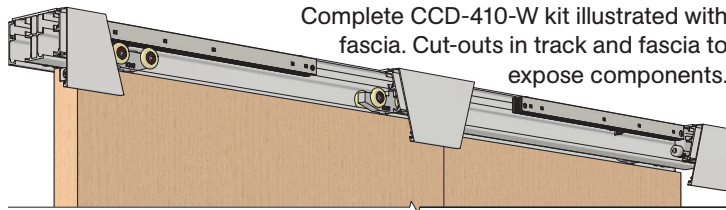

Complete CCD-410-W kit illustrated with fascia. Cut-outs in track and fascia to expose components.

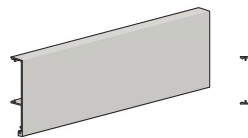

CC-440 Snap-on Fascia x length
Length = Same as track length, example:
72 in [1829 mm] track = 72 in [1829 mm] fascia

Elevation View

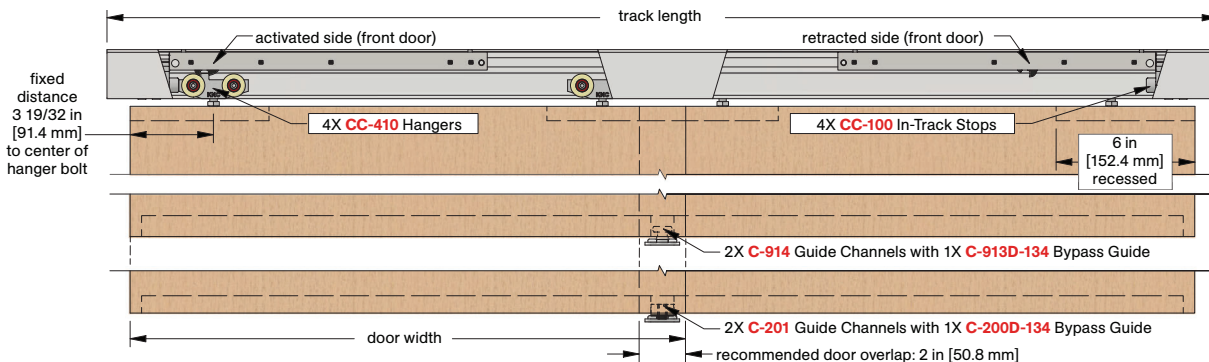

Product Details and Dimensions

Section View

Optional CC-440 Snap-on Fascia illustrated as solid black profile

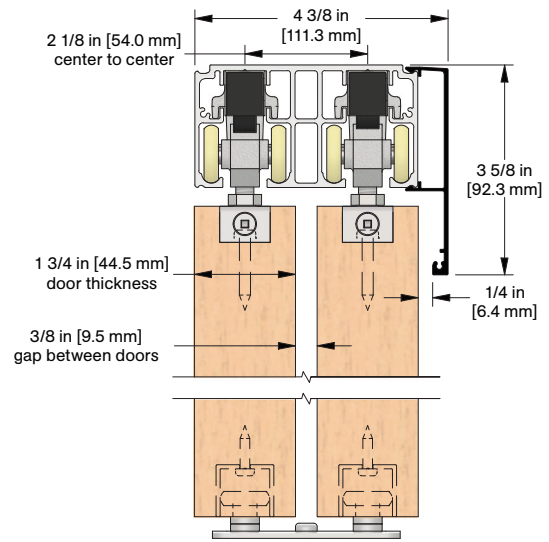
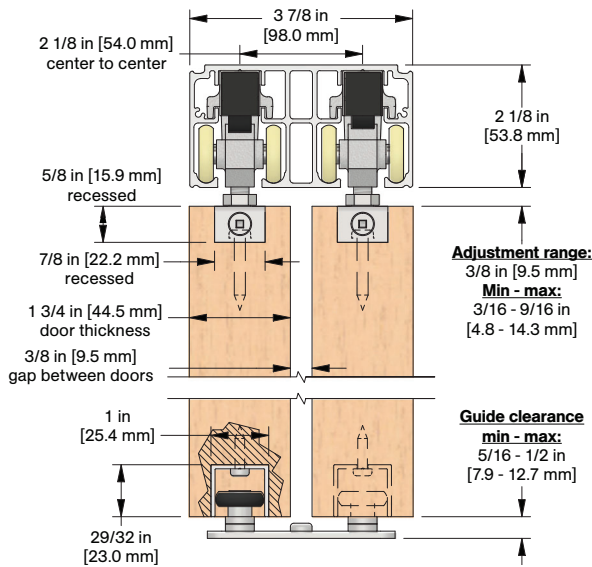

CCD-410-W

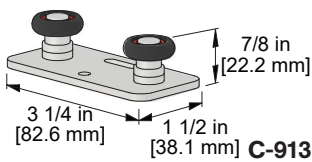

C-913D-134 Bypass Double Guide (1)

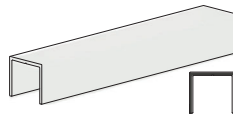

C-914 Guide Channel x length (2)

Length = door width, example:
36 in [914 mm] door = 36 in [914 mm]
guide channel less set-backs if desired

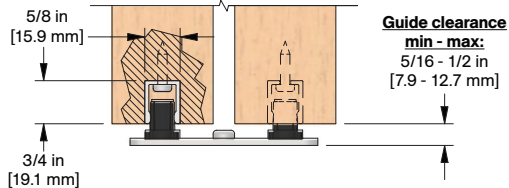
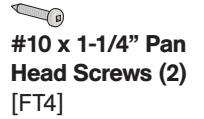
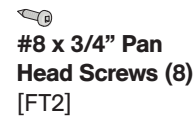

CCD-410-B

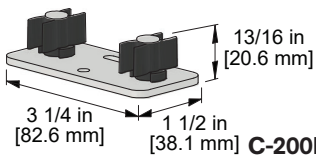

C-200D-134 Bypass Double Guide (1)

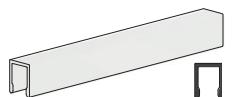

C-201 Guide Channel x length (2)

Length = door width, example:
36 in [914 mm] door = 36 in [914 mm]
guide channel less set-backs if desired

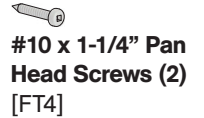
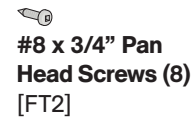

Typical installation location for floor guides

For bypassing applications

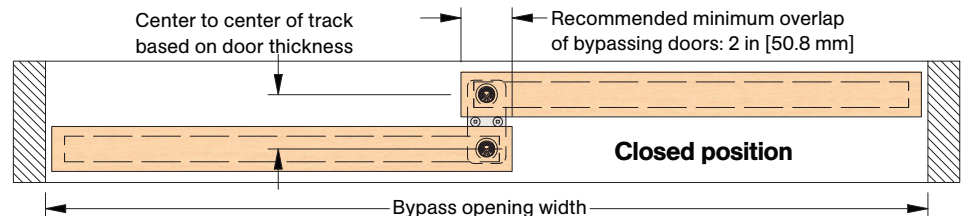

Installation Steps

Step #1:

Determine door size, header height, track position, and bottom clearance based on kit code ordered by using dimensions shown in detail views on previous page.

Step #2:

Note: If access to the ends of track is not available, steps #3 and 4 must be completed before step #2.

Cut CC-500 aluminum track to size if required (typically 2 x the door width). Locate and pre-drill holes in mounting flange on track. Secure track to structural support/backing.

Note: Starting hole locations at each end of track should be 1/2 in [12.7 mm] from end and then 19 in [482.6 mm] from first hole. Minimum #10 screws or 1/4 in [6.3 mm] structural bolts recommended to secure track. Solid backing is required. Spacing is recommended to be between 12-16 in [304-406 mm] on center. Consult structural engineer to ensure adequate support and fastening.

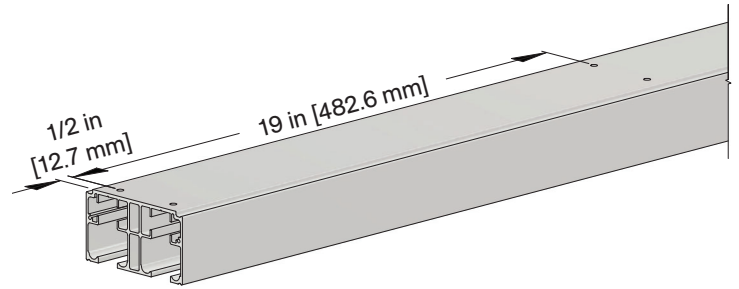

Step #3:

Assemble CC-410 Catch 'N' Close Hangers as shown below:

Fig. 1 Locate CC-410 Hex Head Bolt into hole on CC-410-CB 'C'-Bar from underside as shown below.

Thread CC-410-LN Lock Nut onto hex head bolt from reverse side with collar of CC-410-LN Lock Nut against CC-410 'C'-Bar as shown below, 2 x required.

Fig. 2 Thread assembly from **Fig. 1** into CC-400 Hanger Body from underside, side opposite the trigger, do not thread in fully.

Completed CC-410 Hanger assembly, 2 x required.

Fig. 3 Shows underside of complete assembly with CC-410 Hex Head Bolt locked into place between the flanges of CC-410-CB 'C'-Bar.

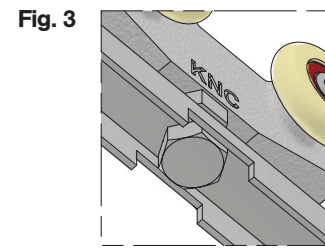
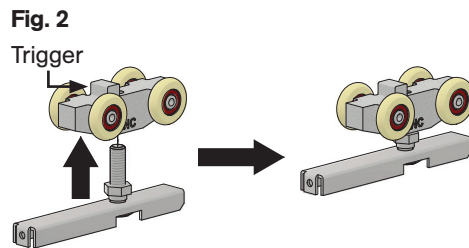
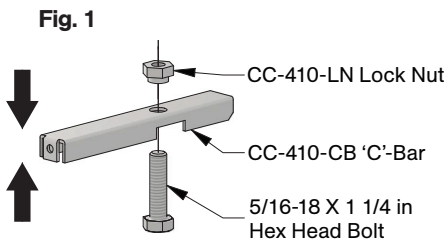

Step #4:

Slide one (1) CC-410 Hanger assembly (✱) with trigger facing end of track and one (1) CC-100 In-Track Stop (●) into each end of track as shown below.

Note: Leave screws on CC-100 In-Track Stops (●) loose to allow stops to slide freely within track. Rubber bumpers of each stop (●) should face inward, toward middle of track.

- ✱ CC-410 Hanger
- CC-100 In-Track Stops

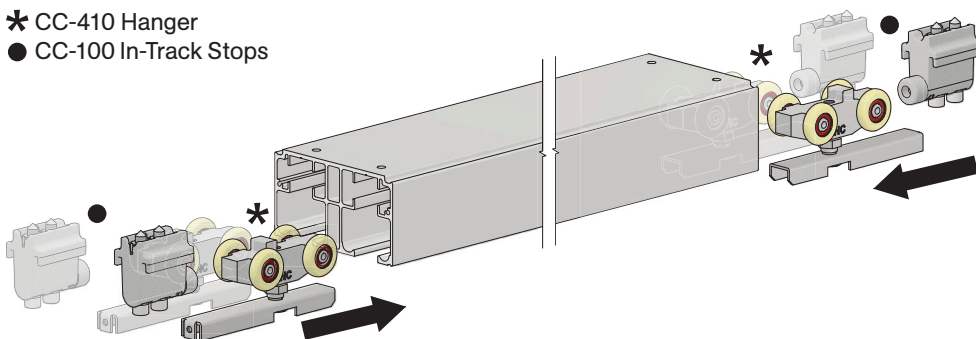
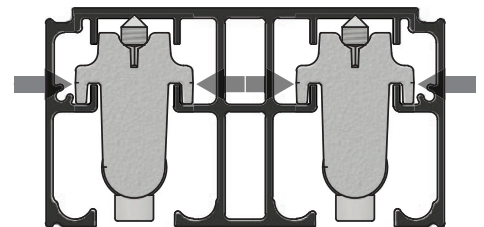
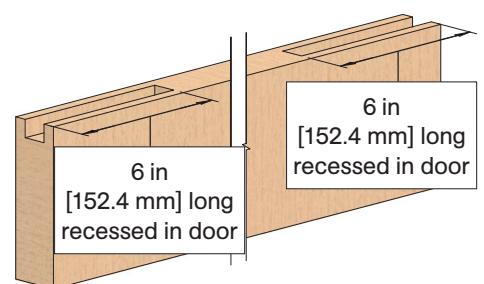
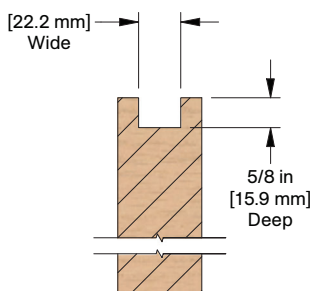

Illustration below shows correct positioning of stops in track



Step #5:

Prepare doors to receive CC-410-UH 'U'-Housing flush with top edge of door. Slots must be 7/8 in [22.2 mm] wide, 5/8 in [15.9 mm] deep, and 6 in [152.4 mm] long. See right.



Note: If doors have sufficient overlap, guide channel can be recessed into door without cutting a full-length slot in door. If guide channel will be fully recessed, it is recommended to have at least 1/2 in [12.7 mm] door material at each end of doors before start of guide channel slot.

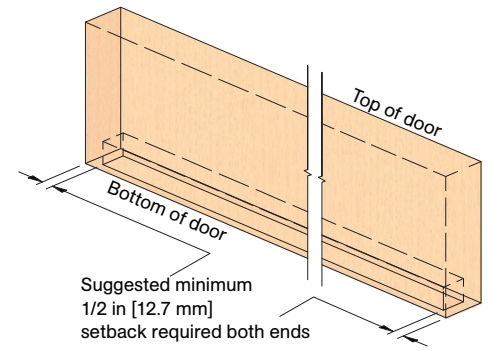

For CCD-410-W

Step #6:

Prepare C-914 Guide Channel Slot in bottom of doors:
 1 in [25.4 mm] wide in center of door,
 29/32 in [23 mm] deep and set back
 1/2 in [12.7 mm] from both edges of doors.
 Make slot as accurate as possible for
 secure fit and neat appearance.

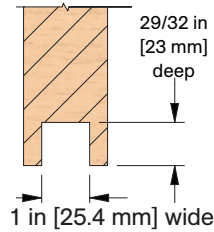

For CCD-410-B

Step #6:

Prepare C-201 Guide Channel Slot in
 bottom of doors:
 5/8 in [15.9 mm] wide in center of door,
 3/4 in [19.1 mm] deep and set back
 1/2 in [12.7 mm] from both edges of doors.
 Make slot as accurate as possible for
 secure fit and neat appearance.

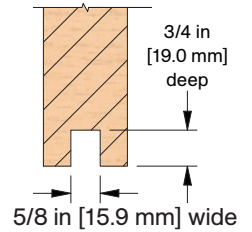

Step #7:

Place CC-410-UH 'U'-Housing into slot created in **step #5** with pin towards the center of the door in order to accommodate CC-410-EC End Cap. See illustration right for details.
 Secure to door with (4) #10 x 1-1/4" Pan Head Screws [FT4]. Repeat for opposite end of door and then other door(s).

3/32 in [2.4 mm] set back required for CC-410-EC End Cap (same on opposite end)

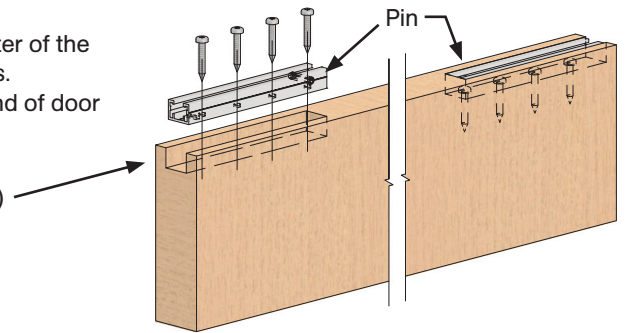

Step #8:

Cut C-914 aluminum guide channel to correct length as required.
 Drill holes in C-914 Guide Channel and pre-drill holes in doors.
 Locate C-914 Guide Channel in slot and secure channel into place
 with (4) #8 x 3/4" Pan Head Screws [FT2].

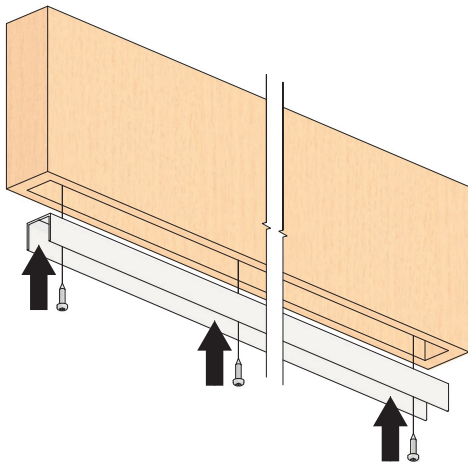

Step #8:

Cut C-201 aluminum guide channel to correct length as required.
 Drill holes in C-201 Guide Channel and pre-drill holes in doors.
 Locate C-201 Guide Channel in slot and screw channel into place
 with (4) #8 x 3/4" Pan Head Screws [FT2].

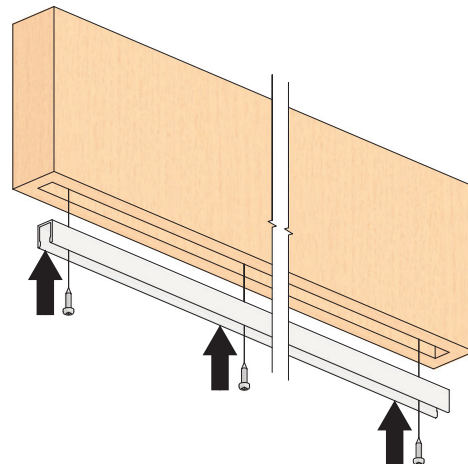

Step #9:

Position C-913D-134 Bypass Guide per
 typical installation location details on page 2
 and secure to floor with two (2) #10 x 1-1/4"
 Pan Head Screws [FT4].

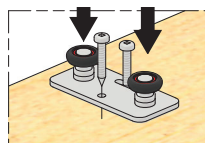

Step #9:

Position C-200D-134 Bypass Guide per
 typical installation location details on page 2
 and secure to floor with two (2) #10 x 1-1/4"
 Pan Head Screws [FT4].

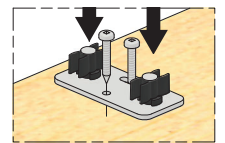

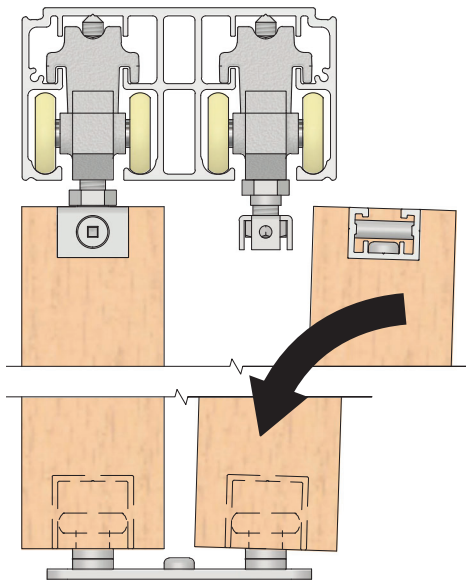

Step #10:

Raise door, position over guide. Slide the CC-410-CB 'C'-Bar into the CC-410-UH 'U'-Housings previously installed on doors.

Note: Threaded end hole must face outward. To make height adjustments, door will need to come off hangers in track, loosen the bolt to the adjustment slot found on the 'c'-bar, adjust and secure accordingly. Repeat step for opposite end of door and then other door(s).

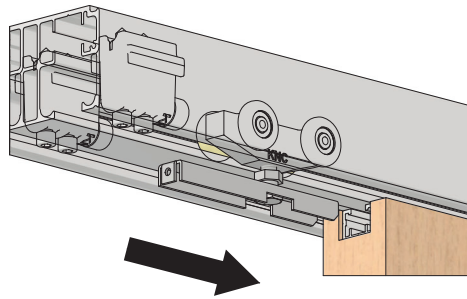

Hanger adjustment view

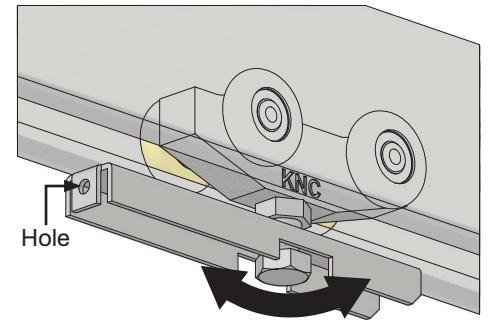

Step #11:

Once adjustments have been finalized, secure CC-410-LN Lock Nut with CP Adjustment Wrench.

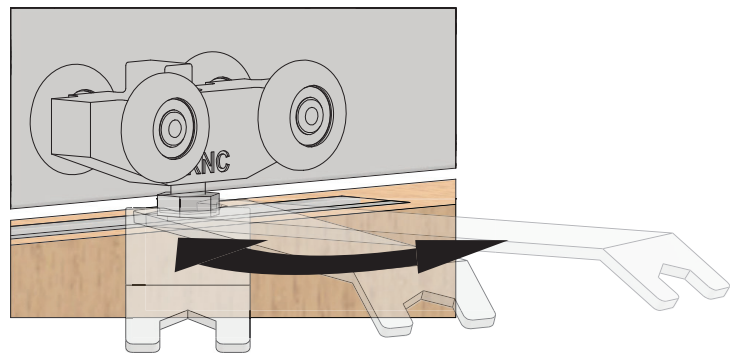

Step #12:

Install CC-410-EC End Caps (4) and secure with (4) #10 x 1-1/4" Flat Head Machine Screws [FT23] as shown below.

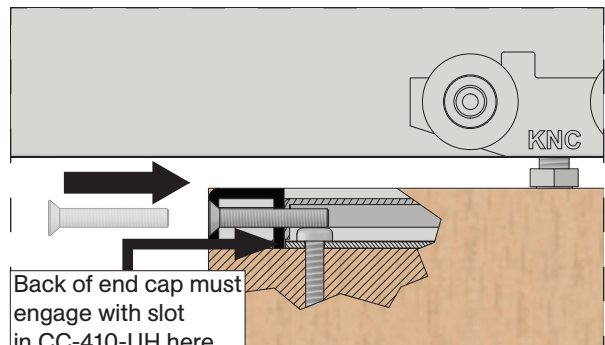
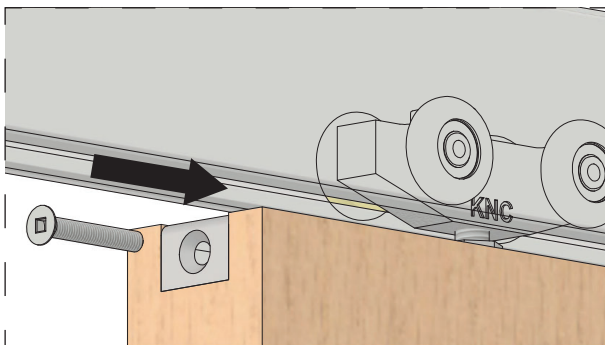
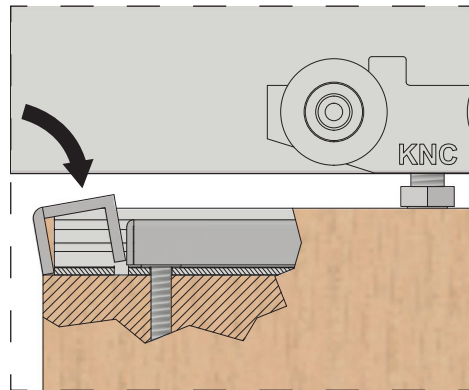
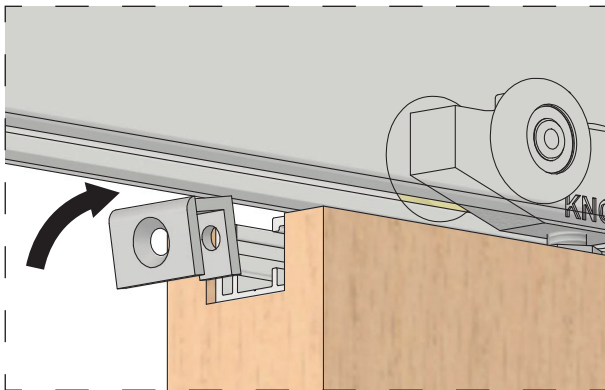

Back of end cap must engage with slot in CC-410-UH here

Step #13:

After doors have been installed, position a door approximately 5-10 in [127-254 mm] away from final position at one end, shown below with left side. Push loose CC-100 Stop, installed in **step #4**, against hanger body.

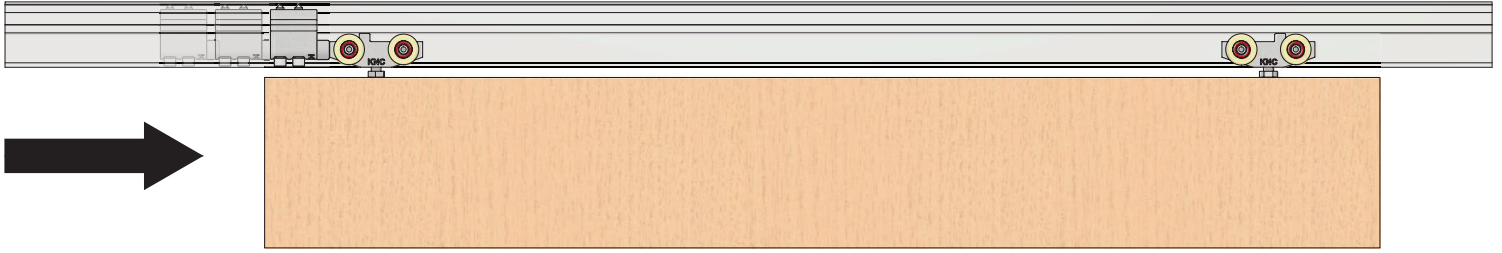

Step #14:

With CC-100 Stop loose, slide door to final/desired position of door as shown below.

Note: Ensure that strike and trim thickness are taken into consideration for final/desired position of door.

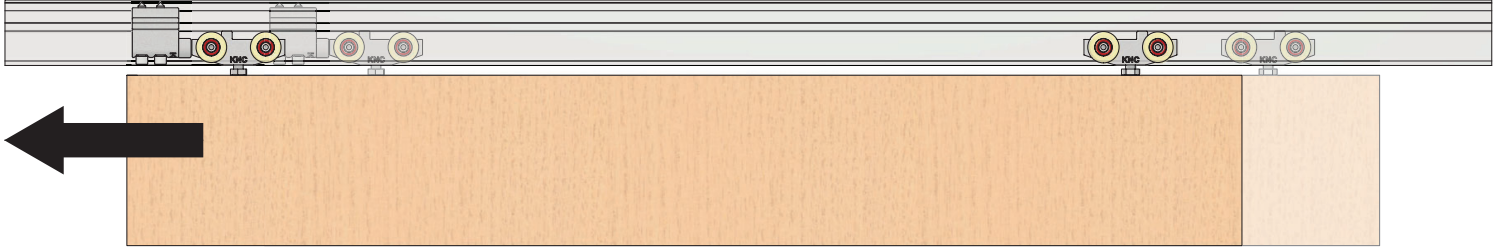

Step #15:

Once final position is achieved, slide door away from CC-100 Stop. Lock CC-100 Stop in position by tightening two cap screws on CC-100 Stop with 3/16 in allen key. CC-100 is secured by friction fit with cone point screws.



Step #16:

Repeat **steps #13 - 15** for opposite side and other door(s).

Note: Ensure that strike and trim thickness are taken into consideration for final/desired position of door.

Step #17:

Before installing Catch 'N' Close Devices, ensure devices are in retracted position as shown below. If not in required position, slide hook down until it locks in position.

Note: Requires significant finger pressure.

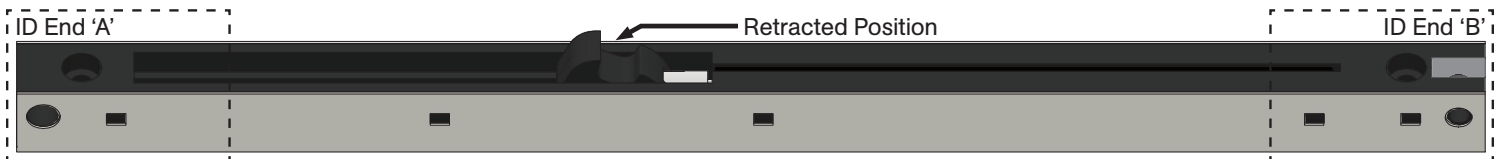

Important Catch 'N' Close Device Notes:

If doors are 75 lbs. [34 kg] or less, ensure CC-75 Catch 'N' Close Devices are used.

If doors are minimum 75 lbs. [34 kg] up to 150 lbs. [68 kg], ensure CC-1 Catch 'N' Close Devices are used.

Step #18:

Place Catch 'N' Close Device into track with leading end 'A' resting against upper body on CC-100 Stops installed previously. See illustrations below.

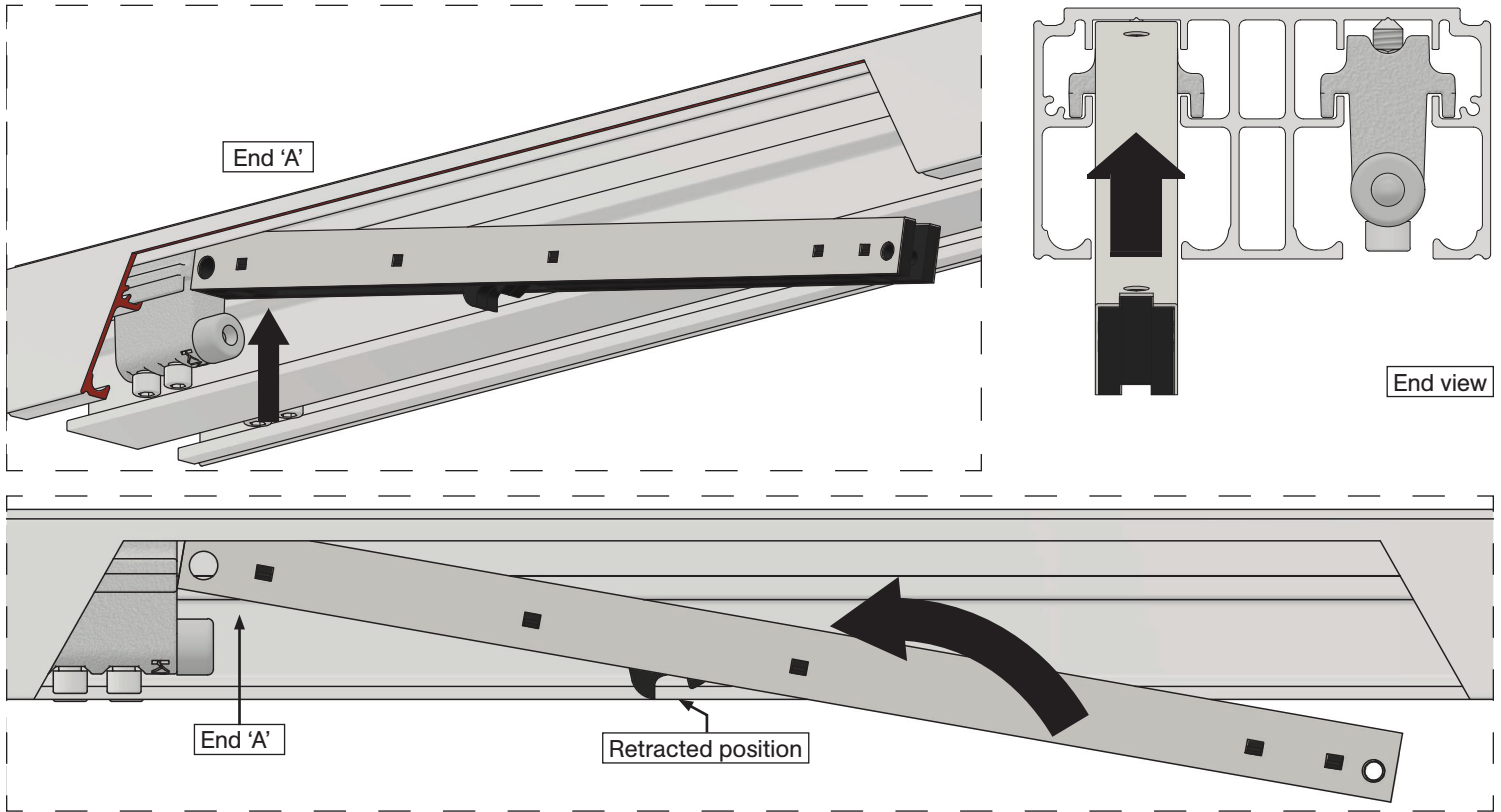

Step #19:

Secure Catch 'N' Close Device to track with (2) #10 x 1-1/2" Self-Drilling Screws [FT5]. Repeat for opposite end with Catch 'N' Close Device installed in reverse as shown on front page in Elevation View illustration. Repeat for other door(s).

Note: If using impact driver to secure Catch 'N' Close Devices, do not overtighten screws. It is recommended to pre-drill track with Ø9/64 in [3.6 mm] drill bit. Secure first screw closest to CC-100 Stop only and test system by sliding door to activate Catch 'N' Close. If it is in correct position, secure with second screw. Remove any drill fillings from inside track.

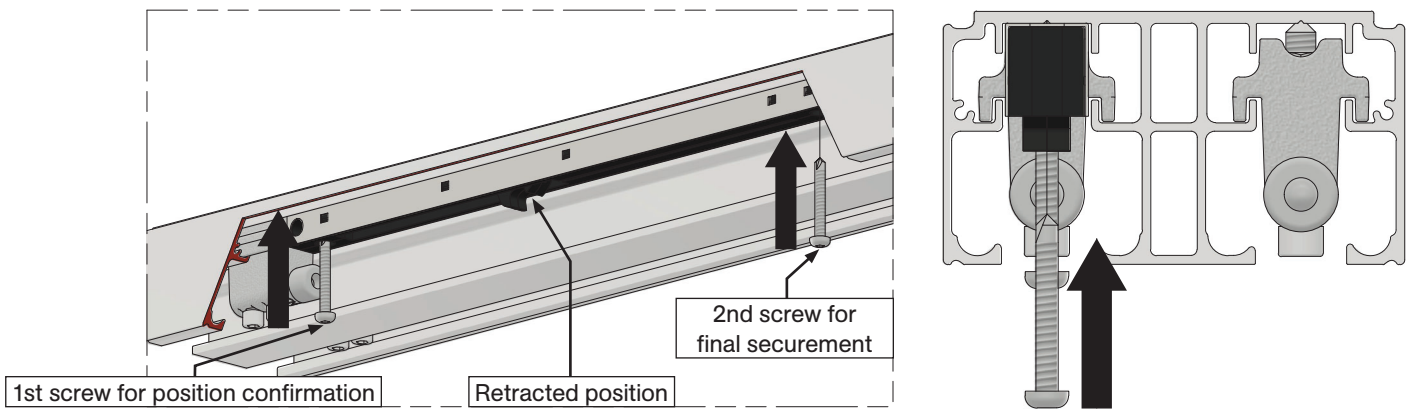

Note: Ensure area of track where Catch 'N' Close Device will be installed is free of fasteners. Securing Catch 'N' Close Device on top of a fastener may lead to operation issues or damage to the system.

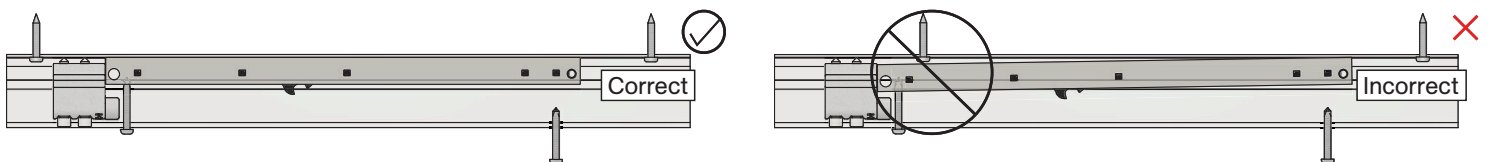

Step #20:

Test complete Catch 'N' Close system by sliding door(s) to both left and right to activate closing devices.

Optional CC-440 Fascia Installation

Step #F1:

Cut CC-440 Fascia to correct length if required. Typically, fascia is same length as track previously installed.

Step #F2:

Lift fascia up to track and snap-on as shown right.

Note: If fascia is loose and a tighter fit is desired, use a rubber mallet on inside leg of fascia to reduce gap at +/-24 in [610 mm] intervals.

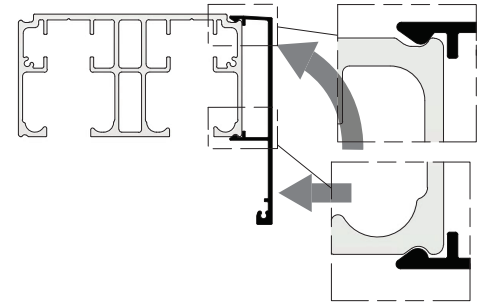
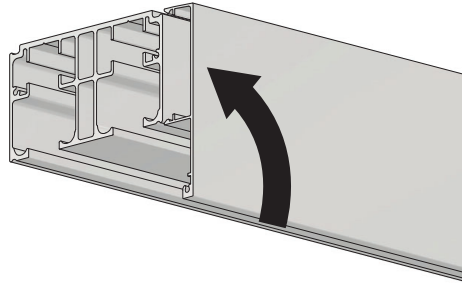

Troubleshooting

Issue	Solution
Chatter/noise when door is sliding	Ensure there are no aluminum shavings within track. Shavings can become embedded in nylon tires and cause noise during operation.
Door is hard to move	Ensure guide channel secured to bottom of door is not over-tightened as this could cause sides of guide channel to “pinch” guide. Remove door and check guide channel by rolling guide roller in channel to ensure smooth travel. There should be little to no resistance. Ensure door is not dragging on bottom of floor/guides and adjust height of door as required.
Door rattles	Ensure locking nuts and screws on hangers are secured and not loose.
Door is not engaging closing device	Ensure hangers are correctly oriented. See steps #3 - 4 . Ensure Catch ‘N’ Close Devices are in correct retracted or extended position prior to sliding door closed/open. See step #17 .
Replacing the Catch ‘N’ Close Device	The Catch ‘N’ Close track and hardware system has been designed for easy installation. Remove two screws that hold Catch ‘N’ Close Device in place and replace device with a new one if failure occurs.