

# CCGH-904

## Installation Instructions

Used with CC-904 Top Mount Track

### Catch 'N' Close System for Glass Doors

- Prevents bouncing and slamming of sliding doors
- Can be installed on both opening and closing ends of doors as narrow as 30 in [762 mm]
- Cycle tested up to 150,000 times
- For 1/2 in [12 mm] or 3/8 in [10 mm] thick glass
- For up to 300 lbs. [136 kg] with CC-3

## Parts List

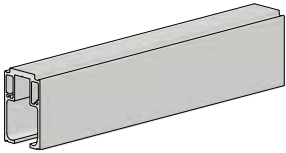

**CC-904 Top Mount Track x length (1)**

Length = 2 x door width, example:

36 in [914 mm] door = 72 in [1829 mm] track

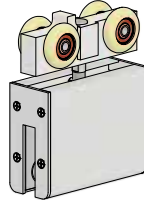

**CCGH-[ ] Hanger (2)**

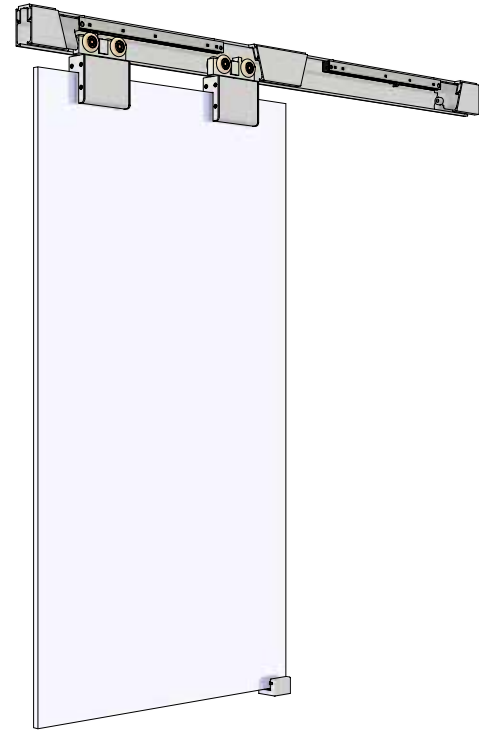

Complete CCGH-[ ] with CC-904 kit illustrated. Cut-outs in track to expose components.

### Disassembled Parts List



**CGH-CB Custom Hanger Bolt (1)**



**CCGH Hanger Body (1)**  
c/w wheels



**3/8-16 Hex Jam Nut (3)**  
[FT20]

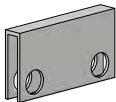

**CGH-RB-[ ] Rubber Boot (1)**



**CGH-F Fascia (2)**

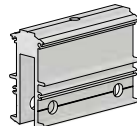

**CGH Aluminum Hanger Body (1)**

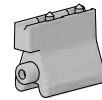

**CC-101HD Catch 'N' Close In-Track Stops (2)**



**Catch 'N' Close Closing Device (2)**  
see details in instruction steps



**CGH Nylon Spacers (2)**



**CGH-GB Glass Bolt (2)**



**CGH-SEC Slotted End Cap (2)**



**#6-32 x 1/2" Flat Phillips Undercut Machine Screw (8)**  
[FT49]



**#10 x 1-1/2" Self-Drilling Screws (4)**  
[FT5]

## Optional Add-on Products

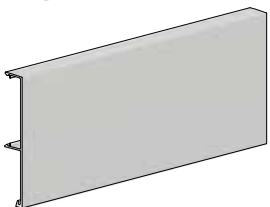

**CC-940 Snap-on Fascia x length**

Length = same as track length, example:

72 in [1829 mm] track = 72 in [1829 mm] fascia

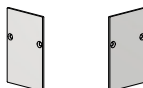

**CC-941 End Caps (2)**  
Left and right

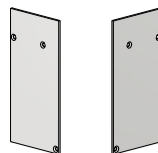

**CC-942 End Caps (2)**  
Left and right

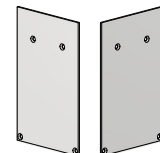

**CC-943 End Caps (2)**  
Left and right



**#4 x 5/16" Flat Head Screws (2)**  
[FT29]

# Product Details and Dimensions

## Elevation View

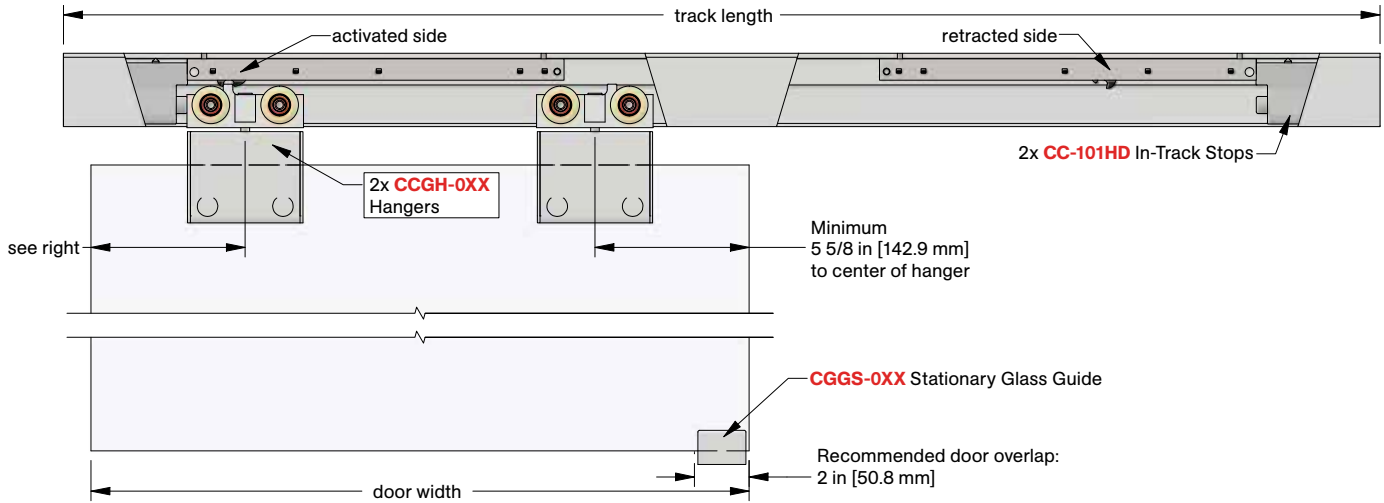

## Section View

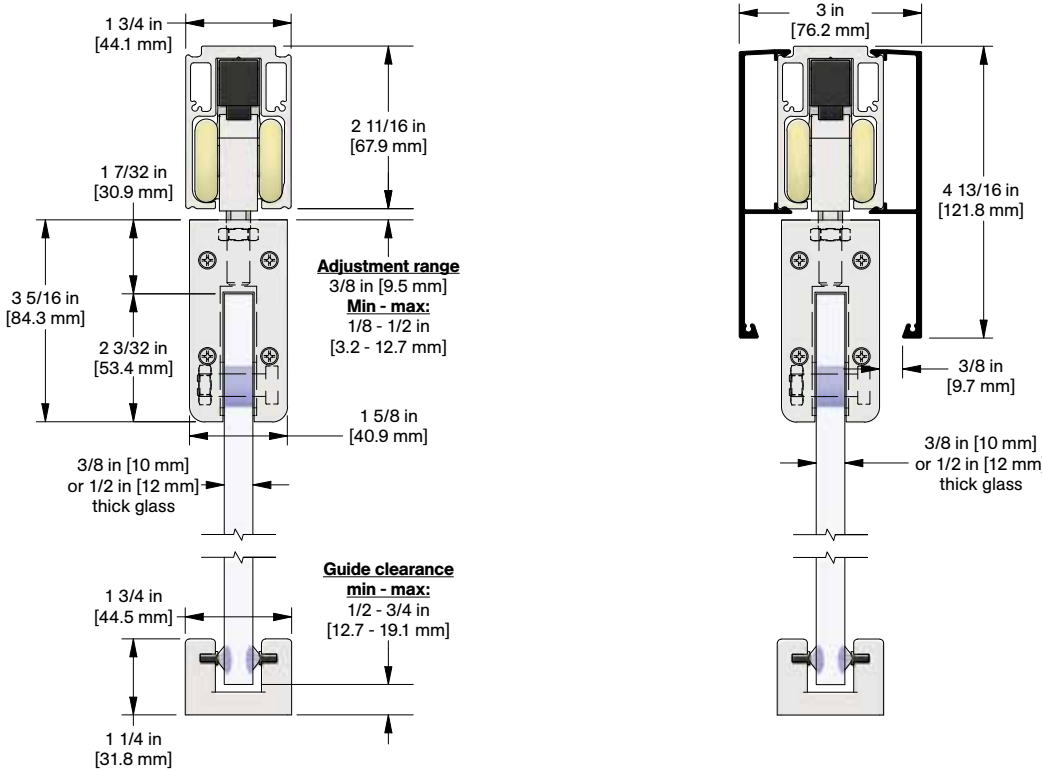

## Typical installation location for floor guides

For pocket door applications

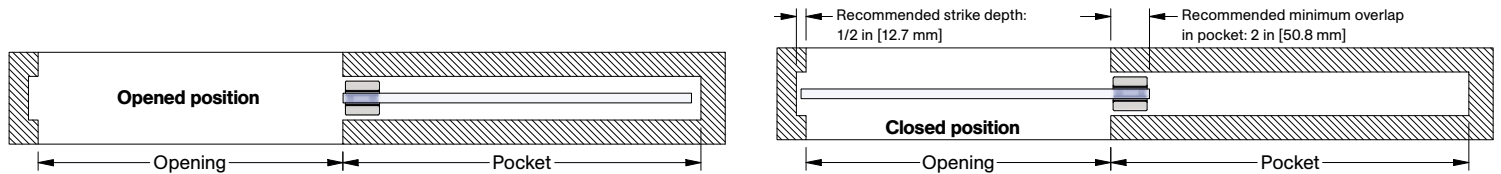

# Installation Steps

## Step #1:

Determine door size, header height, track position, and bottom clearance based on kit code ordered by using dimensions shown in detail views on previous page.

## Step #2:

**Note: If access to the ends of track is not available, steps #3 and 4 must be completed before step #2.**

Cut CC-904 aluminum track to size if required, typically 2x door width. Locate and pre-drill holes through center of track. Secure track to structural support/backing.

**Note: Starting hole locations at each end of track should be 1/2 in [12.7 mm] from end and then 19 in [482.6 mm] from first hole. Minimum #10 screws or 1/4 in [6.3 mm] structural bolts recommended to secure track. Solid backing is required. Spacing is recommended to be between 12-16 in [304-406 mm] on center. Consult structural engineer to ensure adequate support and fastening.**

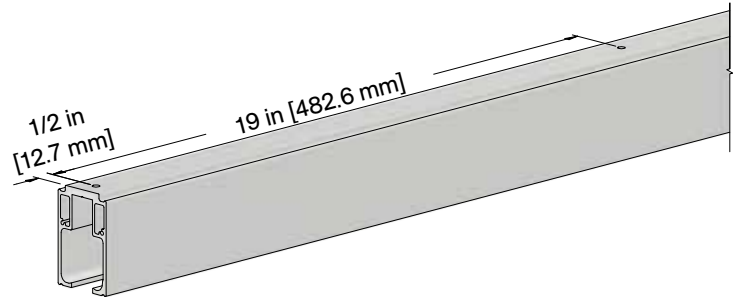

## Step #3:

Assemble CCGH Catch 'N' Close Hangers as shown right:

**Fig. 1** Insert CGH-CB Custom Hanger Bolt into CCGH Hanger Body from top side with trigger, and thread 3/8-16 Hex Jam Nut [FT20] on bolt.

**Fig. 2** Completed CCGH Hanger assembly, 2x required

Fig. 1

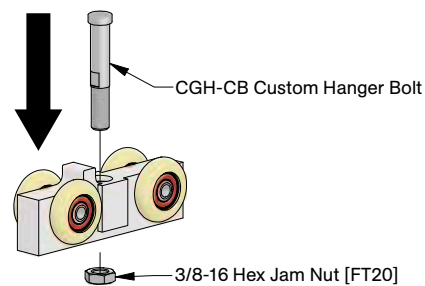
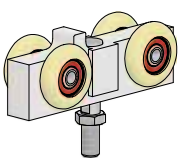

Fig. 2



## Step #4:

Slide one (1) CCGH Hanger assembly (✱) with trigger facing end of track and one (1) CC-101HD In-Track Stop (●) into each end of track, as shown below.

**Note: Leave screws on CC-101HD In-Track Stops (●) loose to allow stops to slide freely within track. Rubber bumpers of each stop (●) should face inward, toward middle of track.**

- ✱ CCGH Hanger
- CC-101HD In-Track Stop

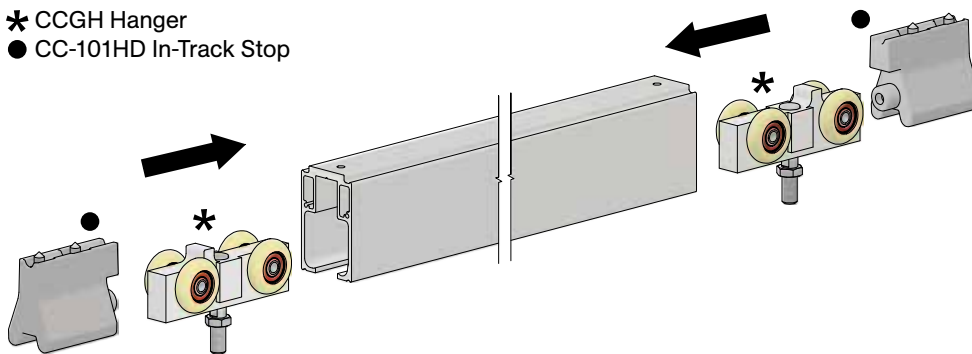
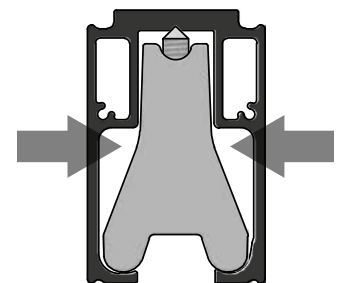
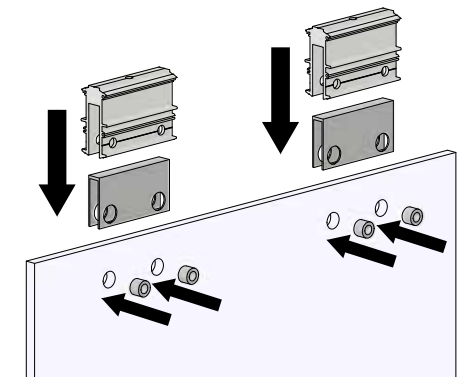

Illustration below shows correct positioning of stops in track



## Step #5:

Prepare glass door with holes per glass prep template attached. Insert CGH Nylon Spacers in prep holes of glass door. Slip CGH-RB [ ] Rubber Boot over top edge of glass, then CGH aluminum hanger body over rubber boot. Align holes on rubber boot and hanger body with CGH Nylon Spacers and holes on glass door. See right.



## Step #6:

Thread (2) CGH-GB Glass Bolts per hanger through holes in glass and into (2) 3/8-16 Hex Jam Nut [FT20]. See below.

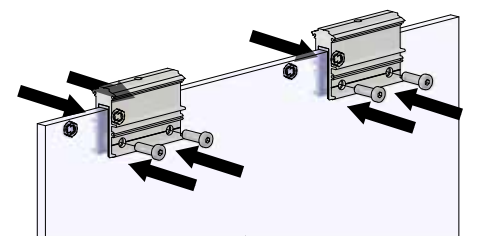

**Step #7:**

Refer to chosen guide installation instructions based on system selected.

**Step #8:**

Raise door, position over guide, and under hangers in track. Lift CGH-CB Custom Hanger Bolt in track and engage with threaded hole on CGH Hanger Body. Adjust door height and plumb by using 5/16 in [7.9 mm] wrench on adjustment flats located on CGH-CB Custom Hanger Bolt. Lock final height adjustment with 3/8-16 Hex Jam Nuts [FT20] using 9/16 in [14.3 mm] wrench.

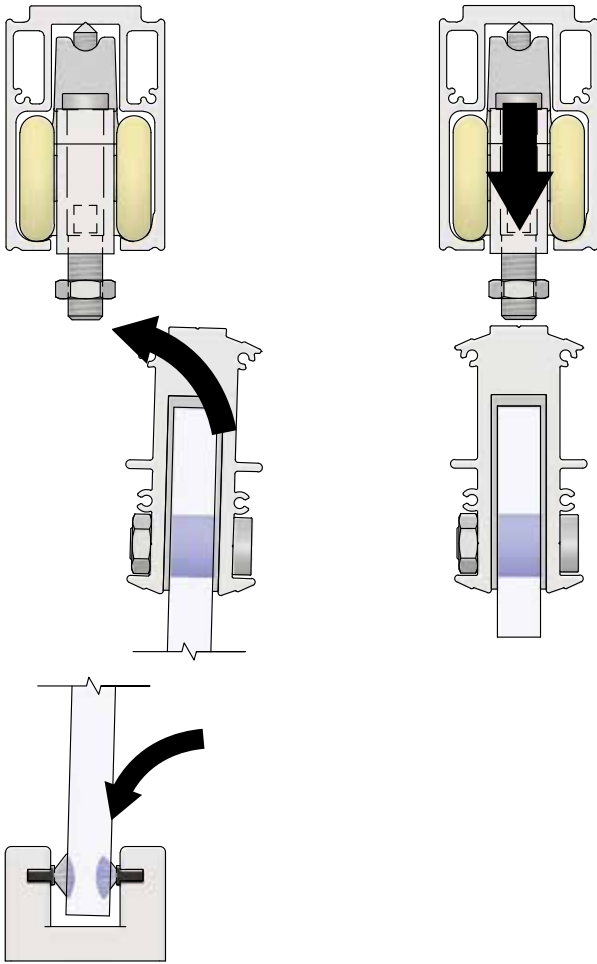

Hanger adjustment view

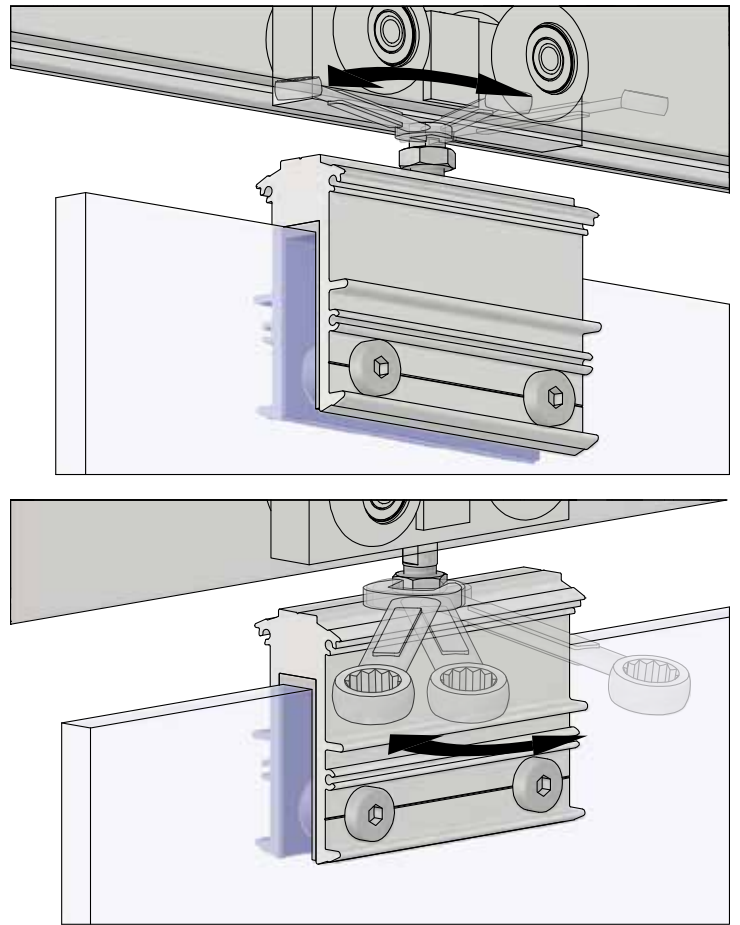

**Step #9:**

Snap CGH-F Fascia onto hanger body, one per side. Place CGH-SEC Slotted End Caps onto ends of each hanger and fasten with (4) #6-32 x 1/2" Flat Phillips Undercut Machine Screw [FT49] per end cap.

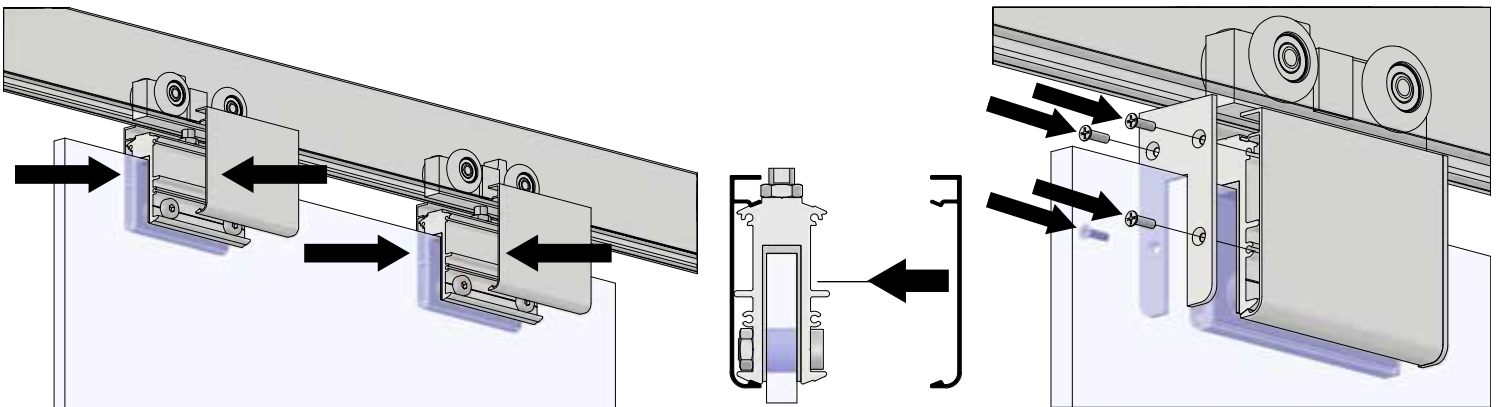

**Step #10:**

After door has been installed, position door approximately 5-10 in [127-254 mm] away from final position at one end, shown below with left side. Push loose CC-101HD Stop, installed in **step #4**, against hanger body.

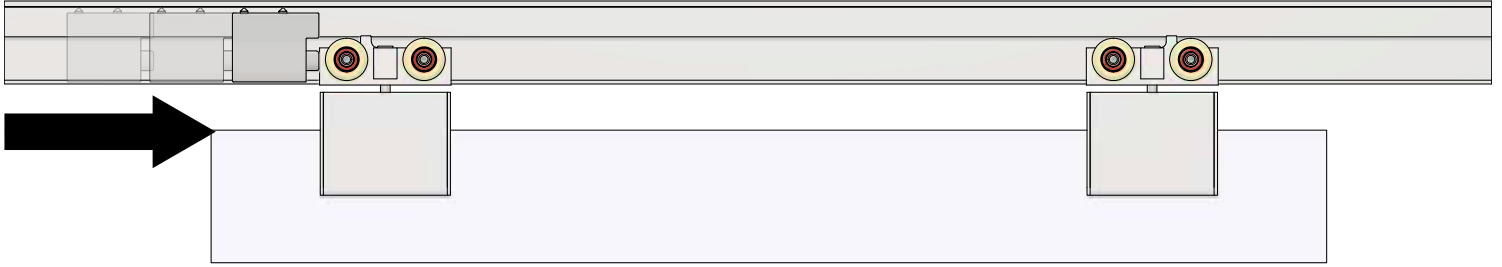

**Step #11:**

With CC-101HD Stop loose, slide door to final/desired position of door as shown below.

**Note: Ensure that strike and trim thickness are taken into consideration for final/desired position of door.**

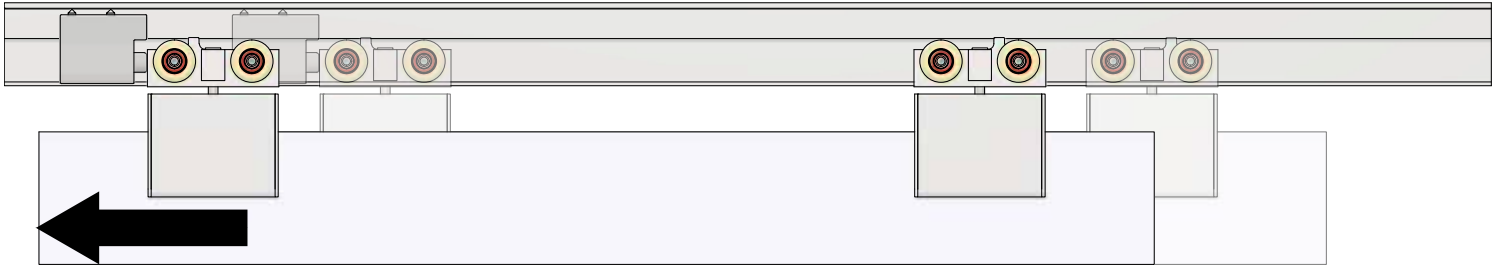

**Step #12:**

Once final position is achieved, slide door away from CC-101HD Stop. Lock CC-101HD Stop in position by tightening two cap screws on CC-101HD Stop with 3/16 in [4.8 mm] allen key. CC-101HD is secured by friction fit with cone point screws.

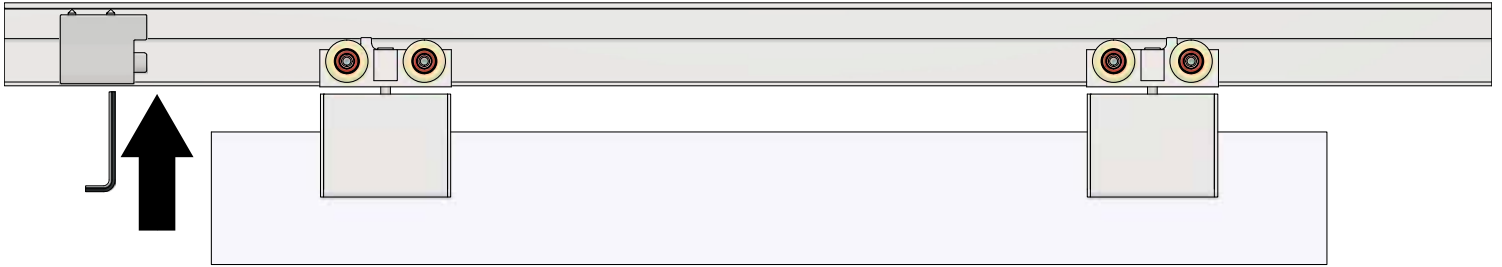

**Step #13:**

Repeat **steps #10 - 12** for opposite side.

**Note: Ensure that strike and trim thickness are taken into consideration for final/desired position of door.**

**Step #14:**

Before installing Catch 'N' Close Closing Devices, ensure devices are in retracted position as shown below. If not in required position, slide hook down until it locks in position.

**Note: Requires significant finger pressure.**

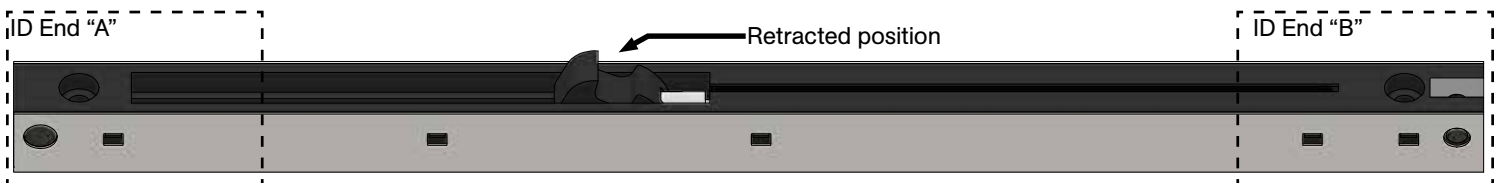

**Important Catch 'N' Close Closing Device Notes:**

If doors are 200 lbs. [90 kg] or less, ensure CC-2 Catch 'N' Close Closing Devices are used.

If doors are minimum 200 lbs. [90 kg] up to 300 lbs. [136 kg], ensure CC-3 Catch 'N' Close Closing Devices are used.

**Step #15:**

Place Catch 'N' Close Closing Device into track with leading end "A" resting against upper body on CC-101HD Stops installed previously. See illustrations right:

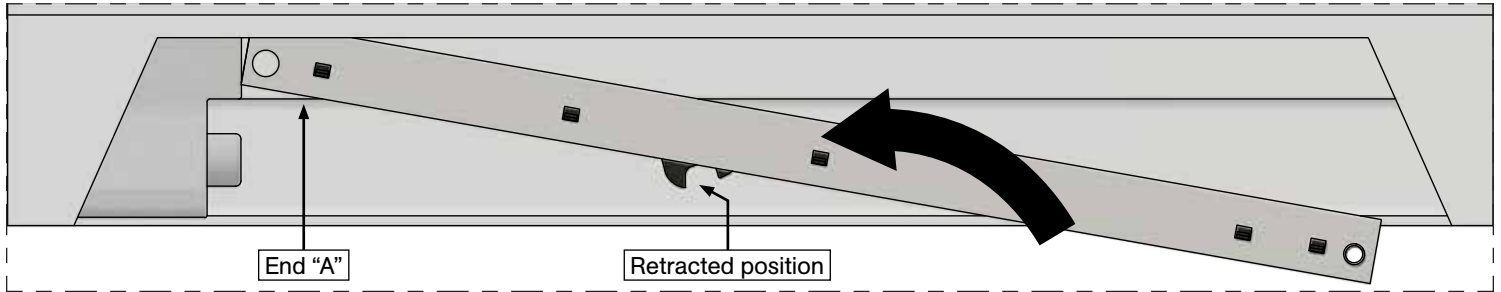

**Step #16:**

Secure Catch 'N' Close Closing Device to track with (2) #10 x 1-1/2" Self-Drilling Screws [FT5]. Repeat for opposite end with Catch 'N' Close Closing Device installed in reverse as shown on front page in "Elevation View" illustration.

**Note: if using impact drive to secure Catch 'N' Close Devices, do not overtighten screws. It is recommended to pre-drill track with Ø9/64 in [3.6 mm] drill bit. Secure first screw closest to CC-101HD Stop only and test system by sliding door to activate Catch 'N' Close. If it in correct position, secure with second screw. Remove any drill fillings from inside track.**

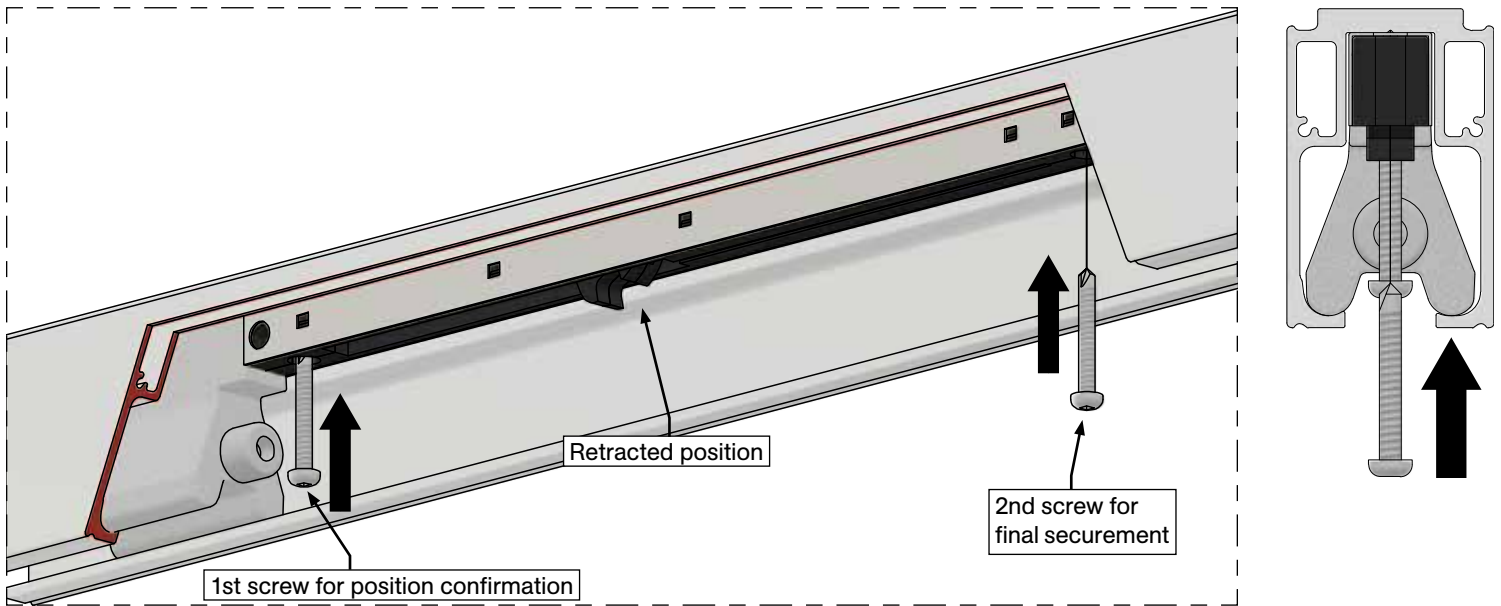

**Note: Ensure area of track where Catch 'N' Close Device will be installed is free of fasteners. Securing Catch 'N' Close Device on top of a fastener may lead to operation issues or damage to the system.**

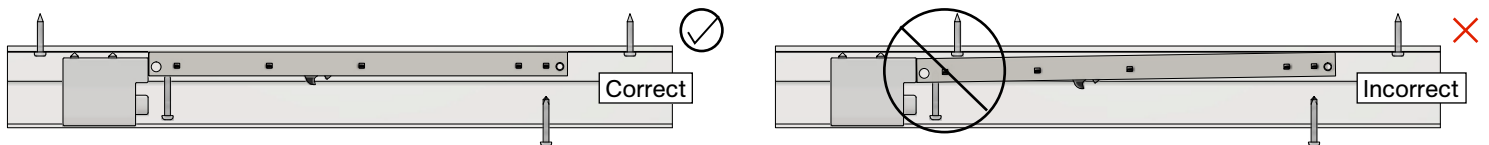

**Step #17:**

Test complete Catch 'N' Close system by sliding door to both left and right to activate closing devices.



# Optional CC-940 Fascia and CC-941/CC-942/CC-943 End Cap Installation

## Step #F1:

Cut CC-940 Fascia to correct length if required. Typically, fascia is same length as track previously installed.

## Step #F2:

Lift fascia up to track and snap on as shown right.

**Note: If fascia is loose and a tighter fit is desired, use a rubber mallet on inside leg of fascia to reduce gap at +/-24 in [610 mm] intervals.**

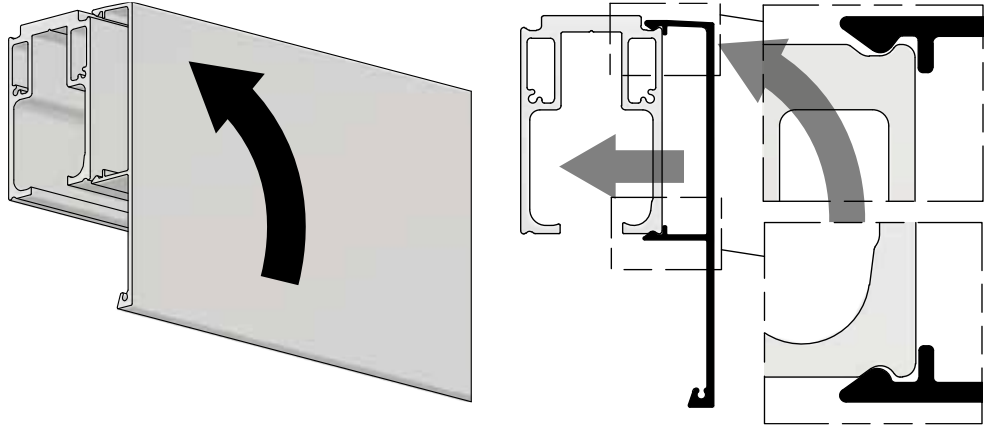

## Step #F3:

Install end cap as shown below with the supplied #4 x 5/16" Flat Head Screws [FT29], 2 - 4 screws per end cap provided..

**Note: Do not install with impact driver.**

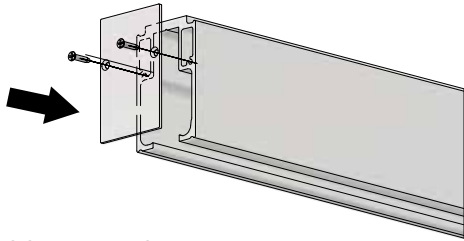

CC-941 End Cap  
with CC-904 Top Mount Track only

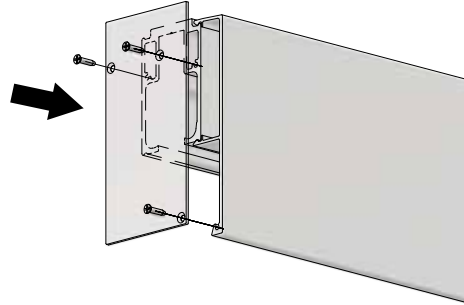

CC-942 End Caps  
with CC-904 Top Mount Track and  
one (1) CC-940 Fascia

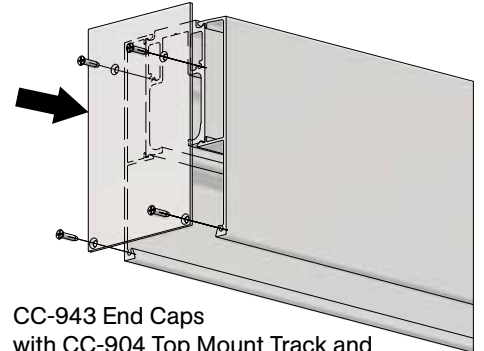

CC-943 End Caps  
with CC-904 Top Mount Track and  
two (2) CC-940 Fascia

## Troubleshooting

Issue	Solution
Chatter/noise when door is sliding	Ensure there are no aluminum shavings within track. Shavings can become embedded in nylon tires and cause noise during operation.
Door is hard to move	Ensure guide channel secured to bottom of door is not over-tightened as this could cause sides of guide channel to "pinch" guide. Remove door and check guide channel by rolling guide roller in channel to ensure smooth travel. There should be little to no resistance. Ensure door is not dragging on bottom of floor/guides and adjust height of door as required.
Door rattles	Ensure locking nuts and screws on hangers are secured and not loose.
Door is not engaging closing device	Ensure hangers are correctly oriented. See <b>steps #4 - 5</b> . Ensure Catch 'N' Close Closing Devices are in correct retracted or extended position prior to sliding door closed/open. See <b>step #15</b> .
Replacing the Catch 'N' Close Device	The Catch 'N' Close track and hardware system has been designed for easy installation. Remove two screws that hold Catch 'N' Close Closing Device in place and replace device with a new one if failure occurs.

# Glass Door Prep Details

