

CF-115 BI-FOLDING DOOR SERIES KIT INSTRUCTION SHEET

FOR 1-3/8" TO 1-3/4" DOORS



PARTS LIST (FOR 2 DOOR KIT)

CF-115 HANGER (1) 	CF-115 2-HOLE TOP PIVOT PLATE (1) 	CF-115 TOP PIVOT STUD (1) 	#10 X 1-1/2" FLATHEAD SCREWS (6) 	EXTRUDED ALUMINUM TRACK
CF-115 ANGLE BRACKETS (3) 	CF-115 3-HOLE BOTTOM PIVOT PLATE (1) 	5/16" -18 X 1-1/4" HEX BOLT (1) 	#10 X 1-1/4" SCREWS (2) 	
		5-16"-18 SQUARE NUT (1) 	#10 X 3/4" SCREWS (6) 	
	CF-115 BOTTOM PIVOT STUD (1) 	5-16"-18 HEX NUT (3) 		

SPECIFICATIONS:
 -LOAD CAPACITY: 50 LBS PER DOOR.
 -FOR 2-DOOR AND 4-DOOR APPLICATIONS
 -HEAVY-DUTY PRECISION BALL BEARING NYLON WHEELS.

INSTALLATION INSTRUCTIONS

STEP 1

DETERMINE DOOR SIZE/HEADER HEIGHT BASED ON DIMENSIONS SHOWN IN DETAIL VIEWS AND CLEARANCE REQUIRED BELOW DOOR:

- MINIMUM OPENING HEIGHT (A) = DOOR HEIGHT + 2-13/16"
- MAXIMUM OPENING HEIGHT (A) = DOOR HEIGHT + 4"

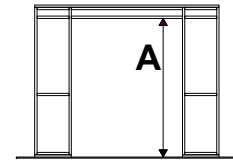

STEP 2

CUT TRACK TO LENGTH. TRACK LENGTH SHOULD EQUAL FINISHED OPENING SIZE LESS 1/8". 1) INSERT 5/16"-18 X 1-1/4" HEX BOT (1) INTO 2-HOLE TOP PIVOT PLATE (1). 2) THREAD SQUARE NUT (1) ONTO BOLT AND 3) SLIDE ASSEMBLY INTO TRACK. 4) INSERT CF-115 HANGER INTO THE OPPOSITE END OF THE TRACK. SECURE TRACK TO HEADER WITH #10 X 3/4" SCREWS (6).

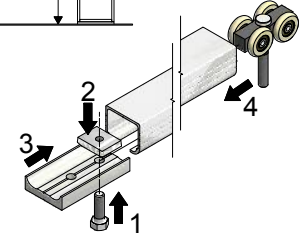

STEP 3

SECURE 3-HOLE BOTTOM PIVOT PLATE TO THE FLOOR WITH #10 X 1-1/4" SCREWS (2). SEE DIMENSION DETAILS FOR DISTANCE PIVOT HOLE TO THE WALL. (EXAMPLE: FOR 1-3/8" DOORS CENTRE OF PIVOT HOLE MUST BE 1-1/4" FROM WALL.)

STEP 4

ROUTER SLOTS IN DOORS FOR ANGLE BRACKETS, ONE ON TOP(A) AND BOTTOM(B) CORNERS OF PIVOTING DOOR AND ONE ON TOP(C) CORNER OF MOVING DOOR. ANGLE BRACKET THICKNESS IS 1/4". SEE DIMENSION DETAILS FOR LENGTH AND HEIGHT.

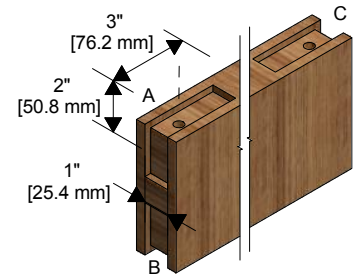

STEP 5

DRILL 3/8" CLEARANCE HOLES FOR PIVOT/HANGER BOLTS AT LEAST 1" DEEP AND 1" FROM ORIGINAL EDGE OF DOOR IN THE SLOTS CREATED IN STEP 4. SEE ILLUSTRATION FOR MORE DETAILS.

STEP 6

PRE-DRILL FOR SCREWS WITH 1/8" DRILL BIT AND SECURE ANGLE BRACKETS TO DOOR WITH #10 X 1-1/2" FLAT HEAD SCREWS (6).

STEP 7

THREAD TOP PIVOT STUD (1) WITH A 5/16" HEX NUT (1) INTO TOP ANGLE BRACKET (A) OF PIVOTING DOOR. THREAD BOTTOM PIVOT STUD (1) WITH A 5/16" HEX NUT (1) INTO BOTTOM ANGLE BRACKET OF PIVOTING DOOR (B).

STEP 8

DOOR SHOULD BE INSTALLED WITH HINGE (BY OTHERS) BY THIS STEP. RAISE DOORS AND THREAD HANGER STUD (HANGER PLACED IN STEP 2) WITH A 5/16" HEX NUT (1) INTO TOP ANGLE BRACKET OF MOVING DOOR (C).

STEP 9

INSERT TOP PIVOT STUD INTO TOP PIVOT PLATE (ON TRACK FROM STEP 2) AND DROP LOWER PIVOT STUD INTO BOTTOM PIVOT PLATE ON FLOOR FROM STEP 3.

STEP 10

USING ADJUSTING NUTS ON BOTTOM PIVOT STUD AND HANGER, ADJUST DOOR FOR PLUMB AND CLEARANCE. USE 5/16" HEX NUTS TO LOCK MODIFICATIONS. WHEN DOORS ARE PROPERLY SET, HANGER SHOULD GUIDE, NOT CARRY THE DOOR.

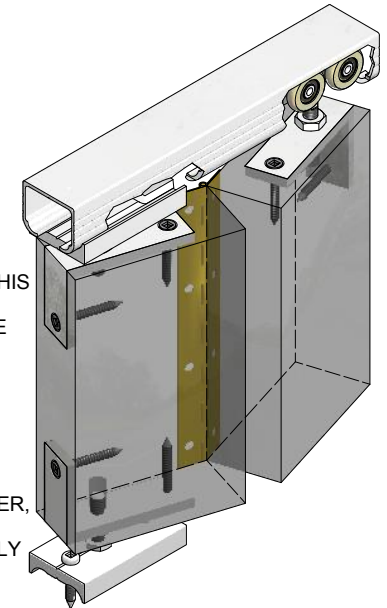

DIMENSION DETAILS:

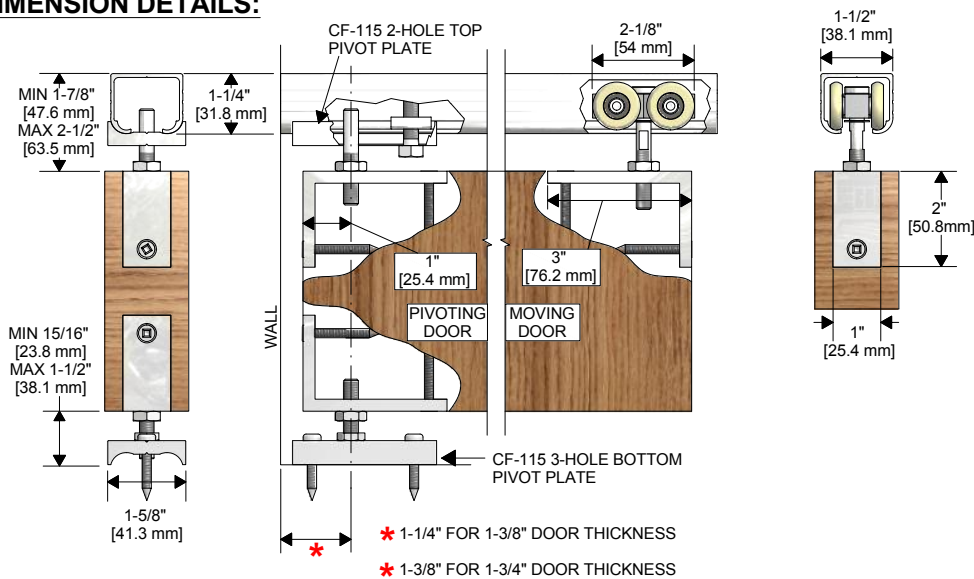

PLAN VIEWS SHOWING CLEARANCE BETWEEN DOORS

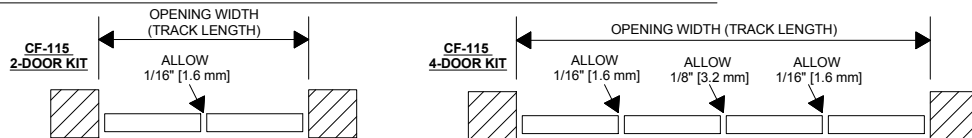

OPTIONAL PRODUCTS

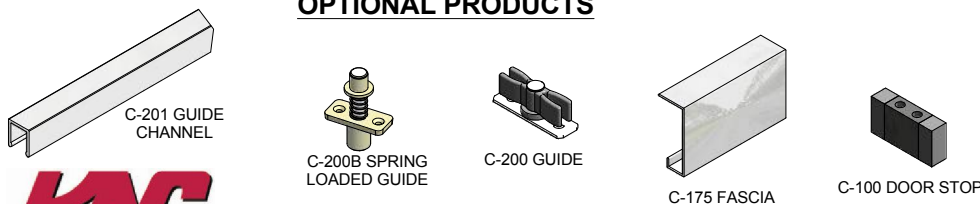

K.N. CROWDER MFG. INC.

1220 BURLOAK DRIVE
 BURLINGTON, ONTARIO, CANADA, L7L 6B3
 TELEPHONE: 905-315-9788
 TOLL FREE FAX: 1-800-567-0123

K.N. CROWDER INC.

210 EIGHTH STREET SOUTH
 LEWISTON, NEW YORK, U.S.A. 14092
 TELEPHONE: 1-716-754-8247
 TOLL FREE FAX: 1-800-567-0123

WEBSITE: www.kncrowder.com -- E-MAIL: customerservice@kncrowder.com