

Crowder Slide

Installation Instructions

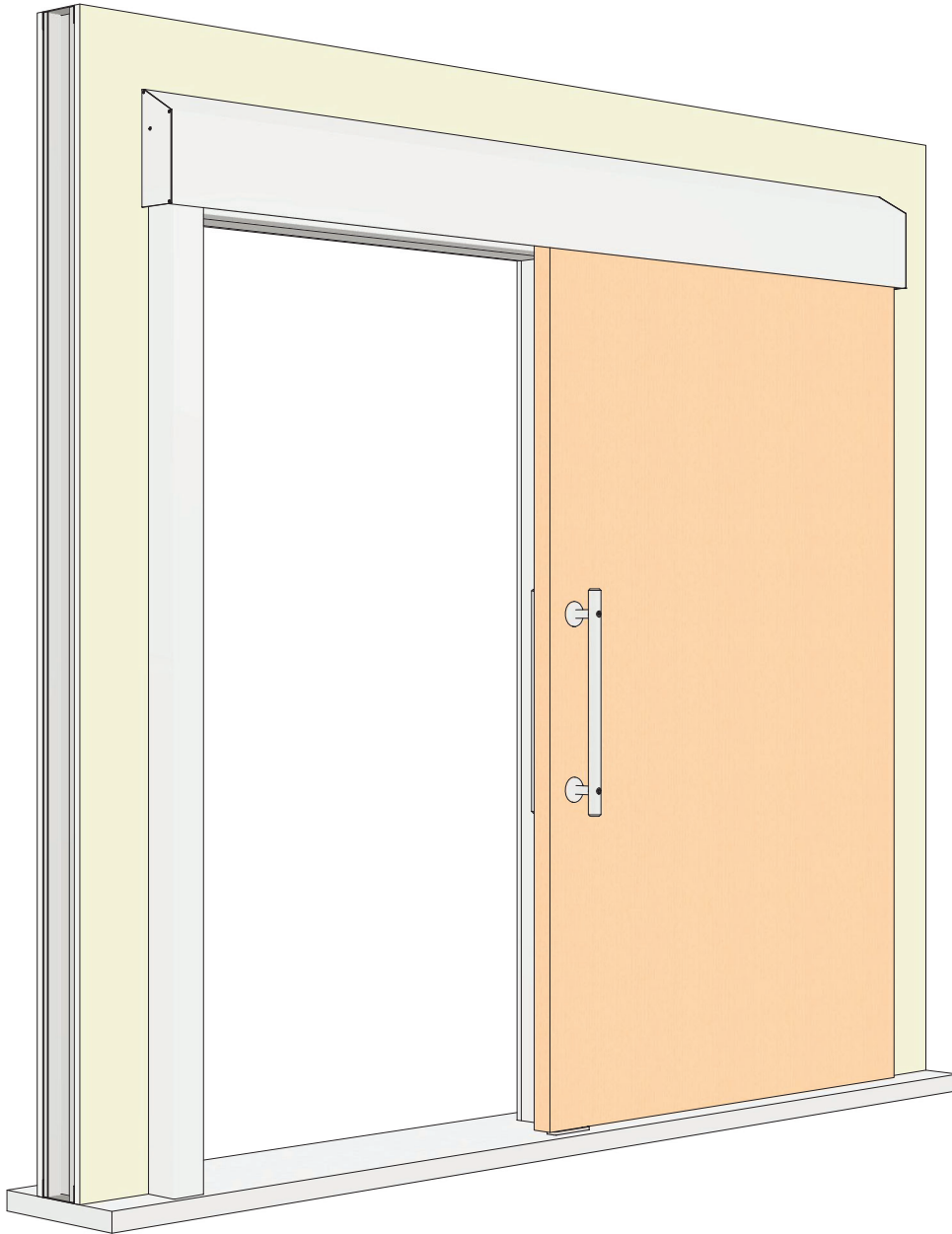

Fascia Style
Sloped

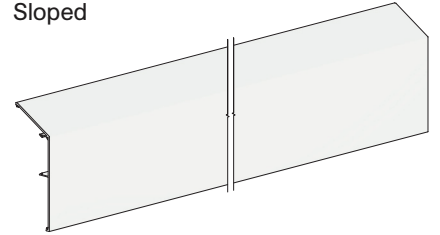

Guide System
C-914/C-913-2

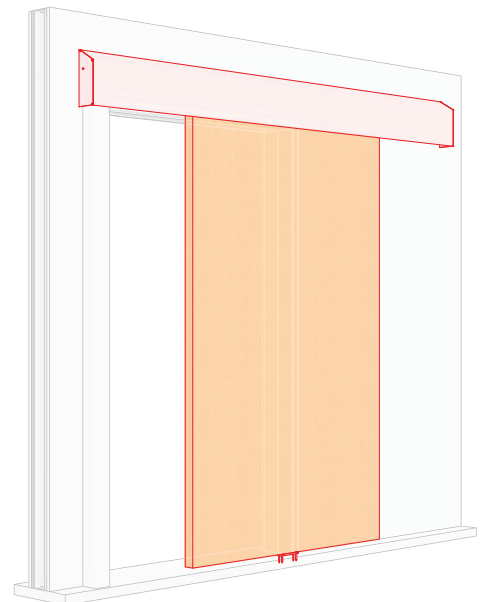
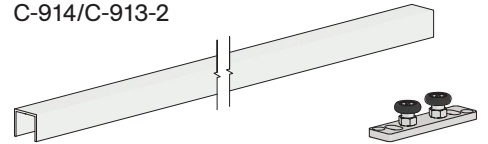

Part 2 of 2

Step #14:

Door Prep

Components required:

Door (not supplied)

Locksets and Pulls (purchased separately)

Prepare Door for C-914 Guide Channel Installation

Rout a slot into bottom edge of door to receive C-914 Guide Channel. Slot must meet following specifications:

- Width: 1 in [25.4 mm]
- Depth: 29/32 in [22.9 mm]
- Setback: 1/2 in [12.7 mm] from both leading and trailing edge of door

Cut slot as precisely as possible to ensure a secure fit and clean, professional appearance once guide channel is installed.

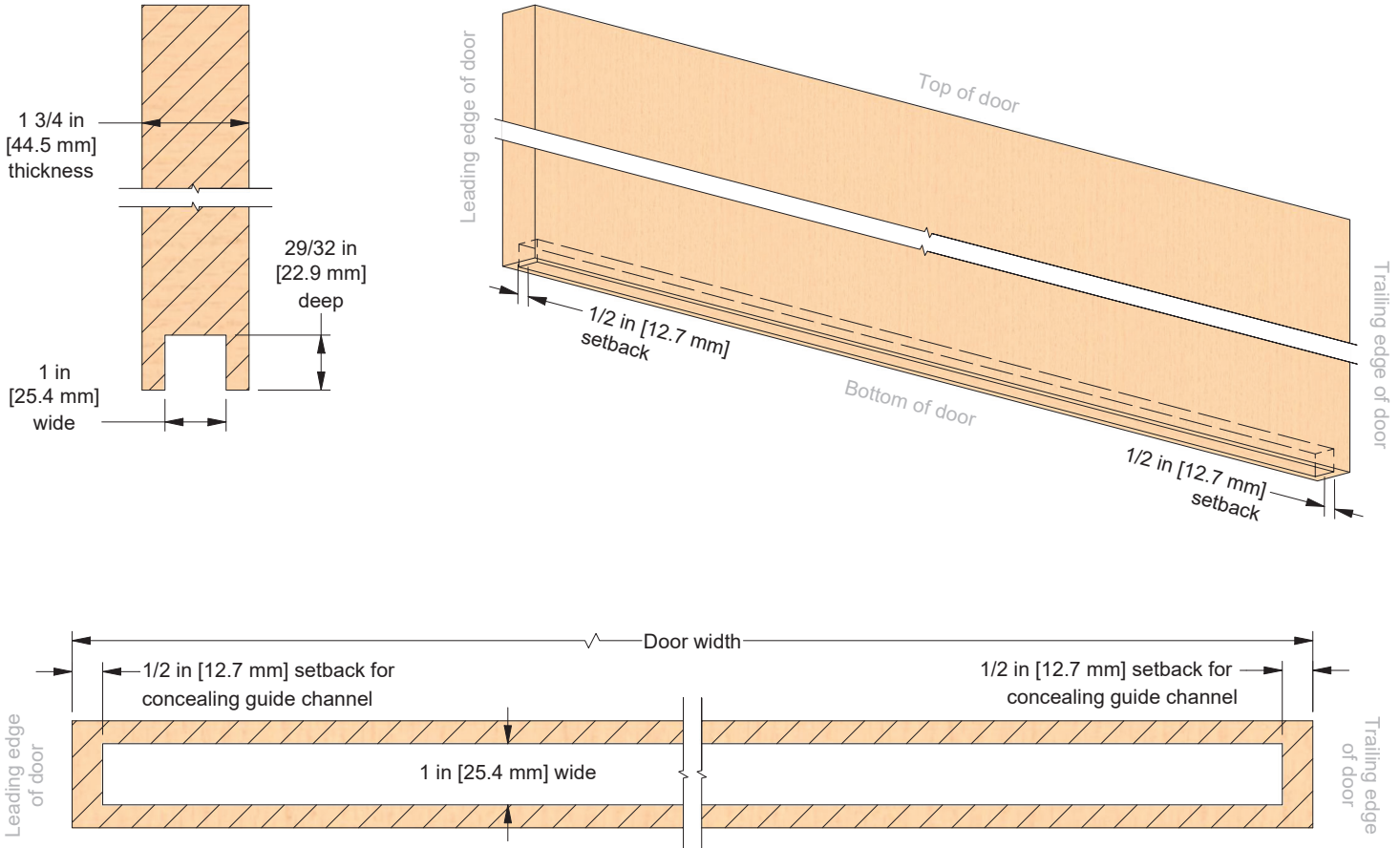

Prepare Door for Locksets and Pulls

If your application includes locksets and pulls (purchased separately), prepare door as required using corresponding templates.

⚠ Important note: Do not install locksets or pulls until full Crowder Slide System is completely installed.

Step #15:

Installing Door Hardware

Components required:

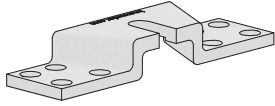

C-998 Top Plates (2)



#12 x 2-1/4" Flat Head Screws (16)
[FT52]



CS-DRT Door Template Tool Set (1)

Pre-install Note

For hollow metal or aluminum doors, it is recommended to drill and tap door and use machine screws by others.

Installing C-998 Top Plates

Separate CS-DRT Door Template Tool Set into two pieces.

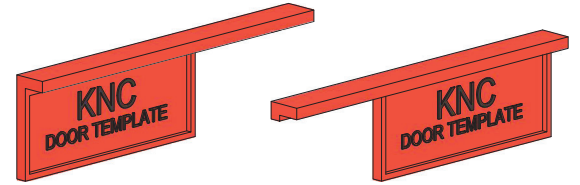

Position one CS-DRT tool on top edge of door, lining up with corner, and supporting it using back face of door. Temporarily secure tool in position using adjustable bar clamps. Place one of C-998 Top Plates against tool, with U-slot facing back face of door. Next, position second CS-DRT tool on opposite side of top plate.

Note: CS-DRT tools are designed to place each top plate:

- 5 5/8 in [142.9 mm] from edge of door
- Centered on a standard 1 3/4 in [44.5 mm] door thickness

If your door thickness differs, manually adjust top plates to ensure they are centered.

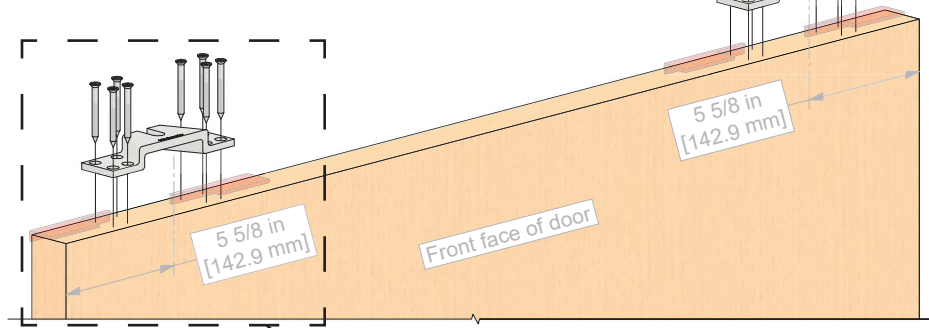
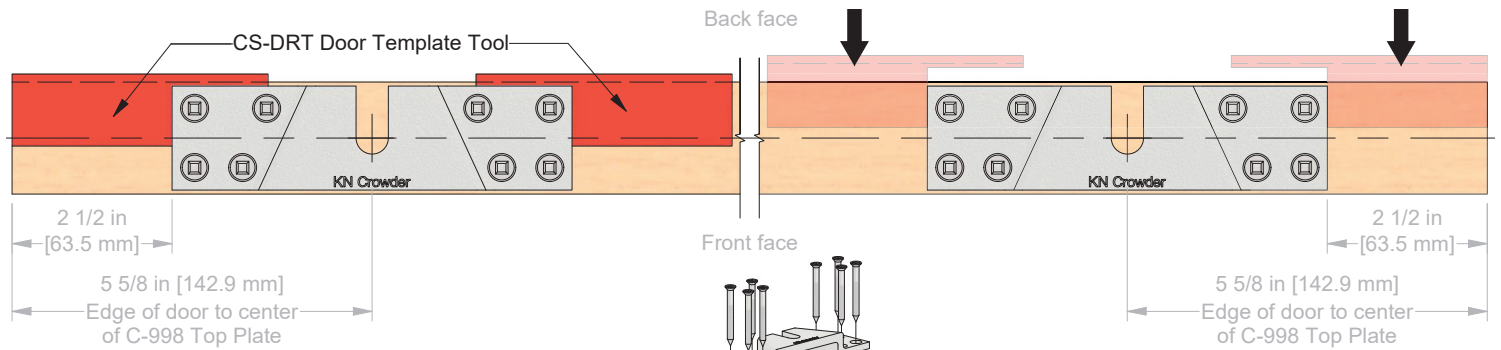

Drill pilot holes through top plate at least 2 1/4 [57.2 mm] deep.

Use the following drill bit sizes:

- Softwood = Ø9/64 in [3.6 mm]
- Hardwood = Ø5/32 in [4.0 mm]

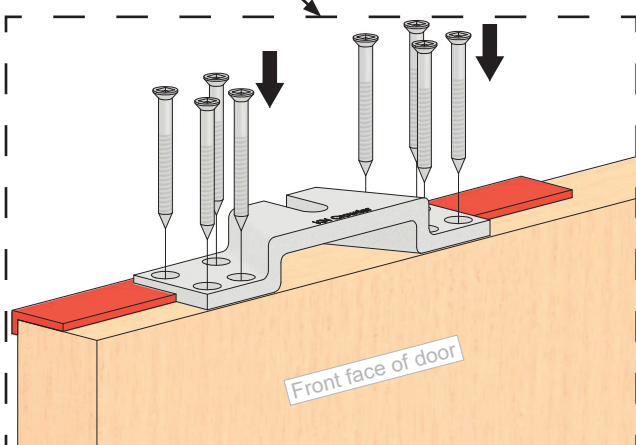

Secure C-998 Top Plates

With CS-DRT tools still clamped in place, secure top plate to door using eight (8) #12 x 2-1/4" Flat Head Screws. Repeat process for second top plate.

Step #15 (continued):

Installing Door Hardware - continued

Components required:

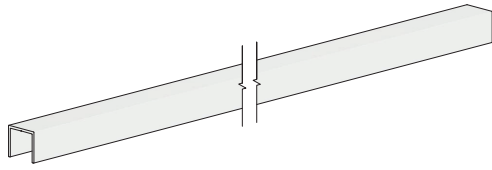

C-914 Guide Channel x length (1)



#8 x 3/4" Pan Head Screws (6)
[FT2]

Installing C-914 Guide Channel

Cut C-914 aluminum guide channel to length of slot routed in **step #14**.

Drill $\text{\O}3/16$ in [4.7 mm] clearance holes along centerline of channel at 8–12 in [200–300 mm] intervals.

Mark and drill pilot holes in bottom edge of door using channel as a template.

Recommended drill bit sizes for wood doors:

- Softwood = $\text{\O}3/32$ in [2.4 mm]
- Hardwood = $\text{\O}7/64$ in [2.8 mm]

Secure guide channel to door with #8 x 3/4" Pan Head Screws (6 supplied).

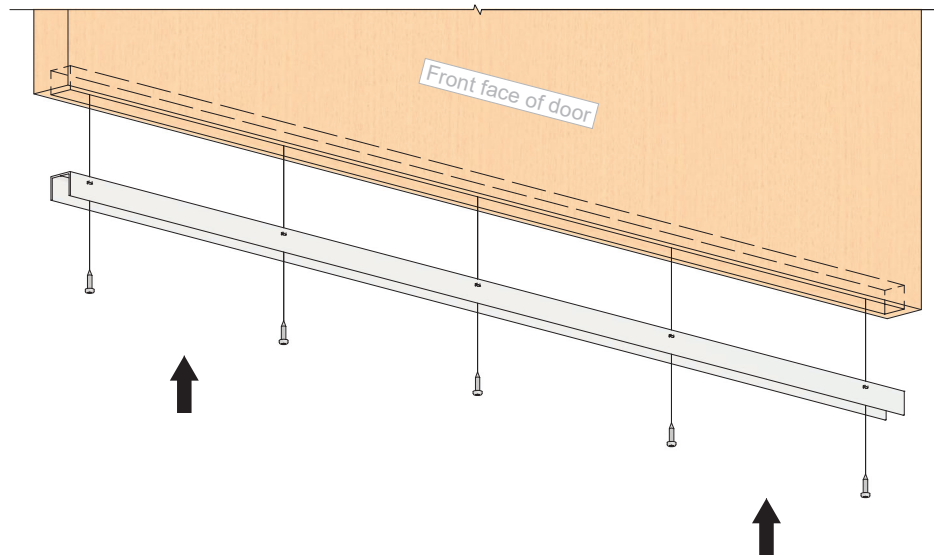

Step #16:

Installing Angled Flat Bar

Components required:



CS-DRT Door Template Tool Set (1)

(CSF3) #6 x 3/4" Flat Head Screws (40)
[FT57]

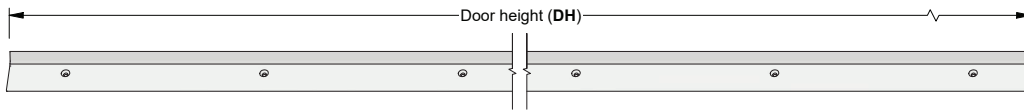

CS-AFB Angled Flat Bar Vertical x door height (1)
Complete with medical-grade TPV gasket

Pre-Install Note

CS-AFB Angled Flat Bar is supplied at a specific length based on door height in Approved Opening Layout Drawing.

Do **not** cut or modify length, as it includes strategically placed holes aligned with door height. If length appears incorrect or needs adjustment, contact KN Crowder for assistance before proceeding.

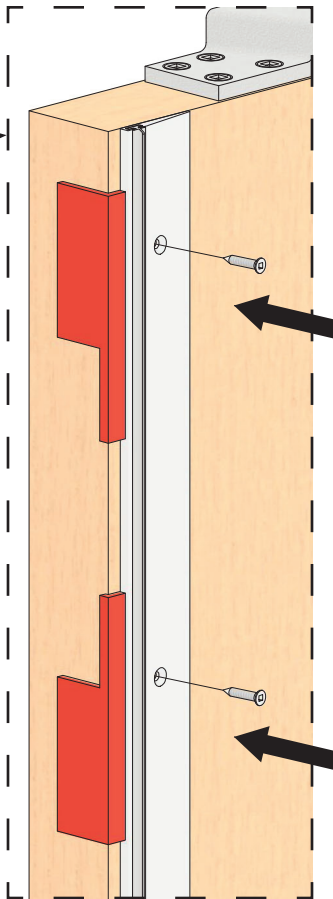
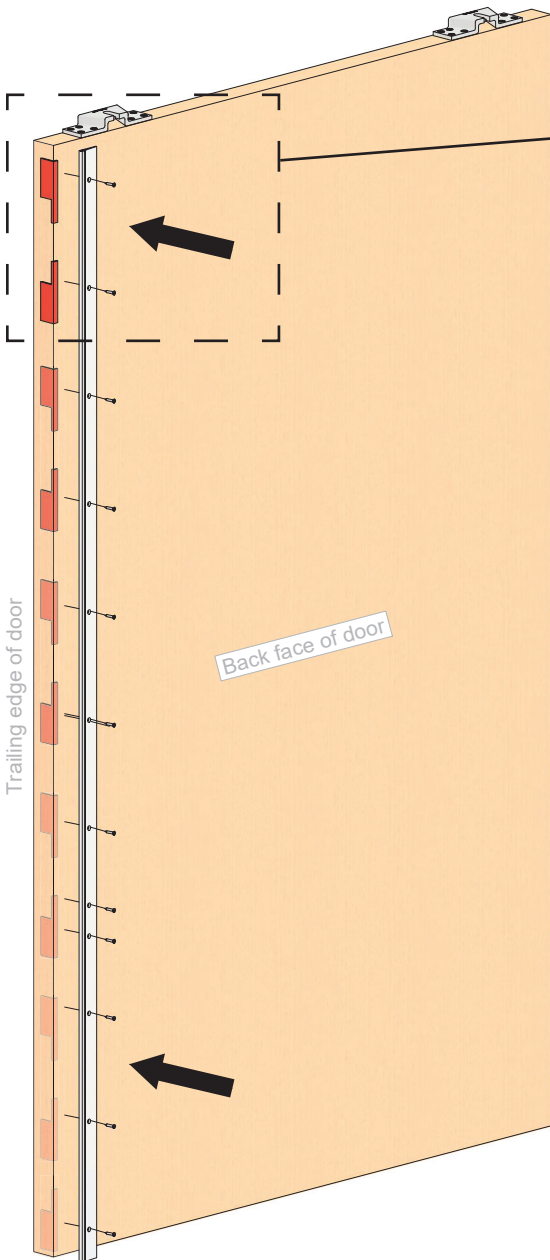

Position and Secure CS-AFB

Use CS-DRT tools as shown, align them with back face and trailing edge of door, starting at top of door.

This positions CS-AFB with a consistent 1/4 in [6.4 mm] setback from trailing edge. Use adjustable bar clamps to temporarily hold CS-DRT tools in place.

Position CS-AFB so that:

- Flat side is flush against back face of door
- Angled portion points toward center of door
- Gasket angles outward toward trailing edge of door

Using countersunk holes in CS-AFB as a guide, mark first two hole locations on door. Drill $\varnothing 5/64$ in [2 mm] pilot holes at each marked location.

Secure CS-AFB to door using #6 x 3/4" Flat Head Screws [FT57].

Reposition CS-DRT tools in 7 in [180 mm] increments moving down door, maintaining a consistent setback.

Continue drilling and securing screws in each remaining countersunk hole to complete installation.

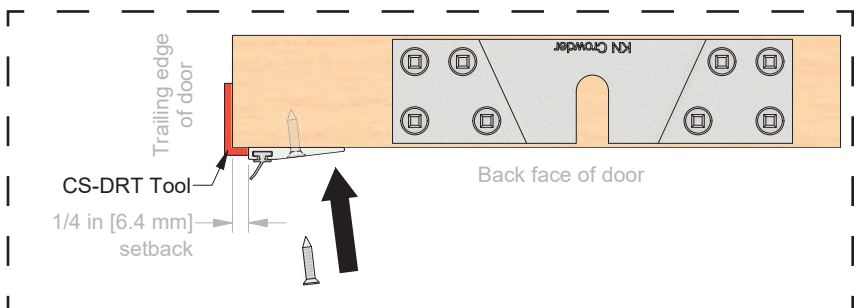

Step #17:

Track Prep

Components required:

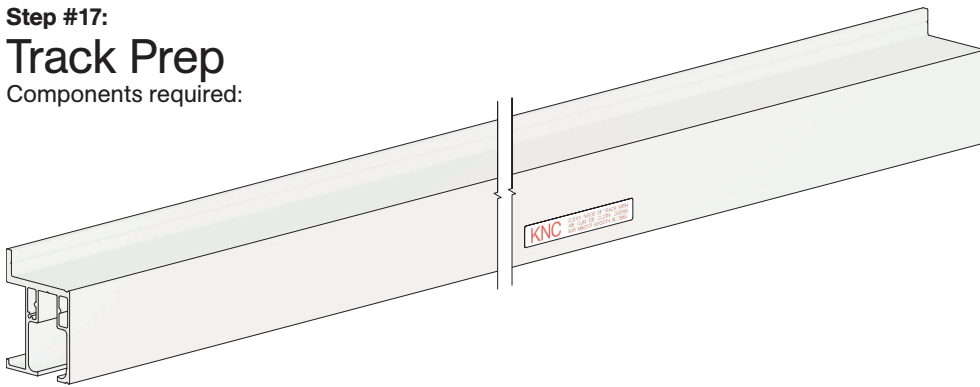

CS-98 Side Mount Track x length (1)

Track Length

CS-98 Track is supplied to length specified in Approved Opening Layout Drawing unless scribe was ordered. If on-site cutting is required, refer to guidelines provided in drawing below to determine appropriate final length.

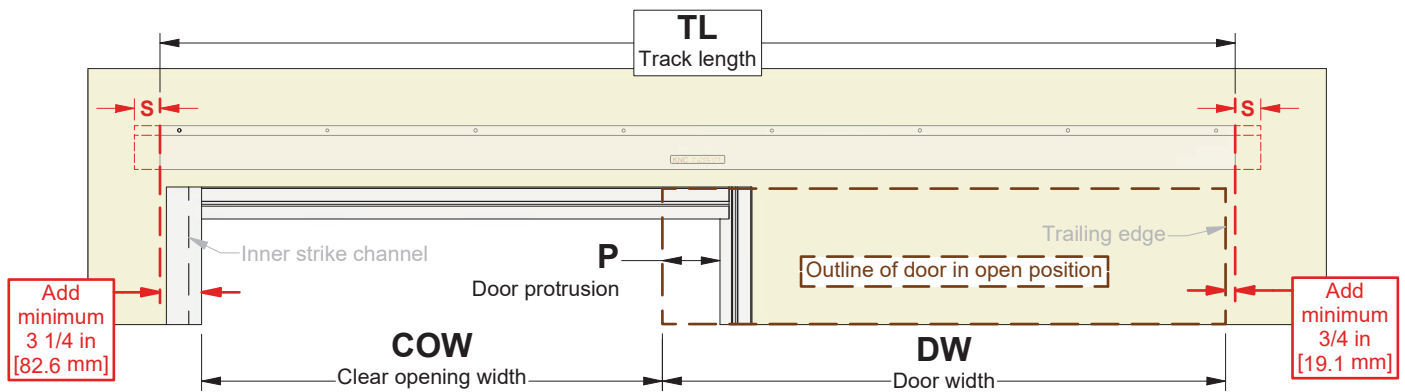

Drill Mounting Holes

Drill clearance holes through mounting flange of CS-98 Track at appropriate intervals.

Note:

- Use a minimum of $\text{Ø}5/16$ in [8 mm] lag bolts or structural bolts, spaced 12–16 in [300–400 mm] on center.
- Proper structural support is required. Always consult a structural engineer to confirm that mounting surface and fasteners are suitable for load and application.

Mounting holes are **not** pre-drilled and must be marked and drilled by installer.

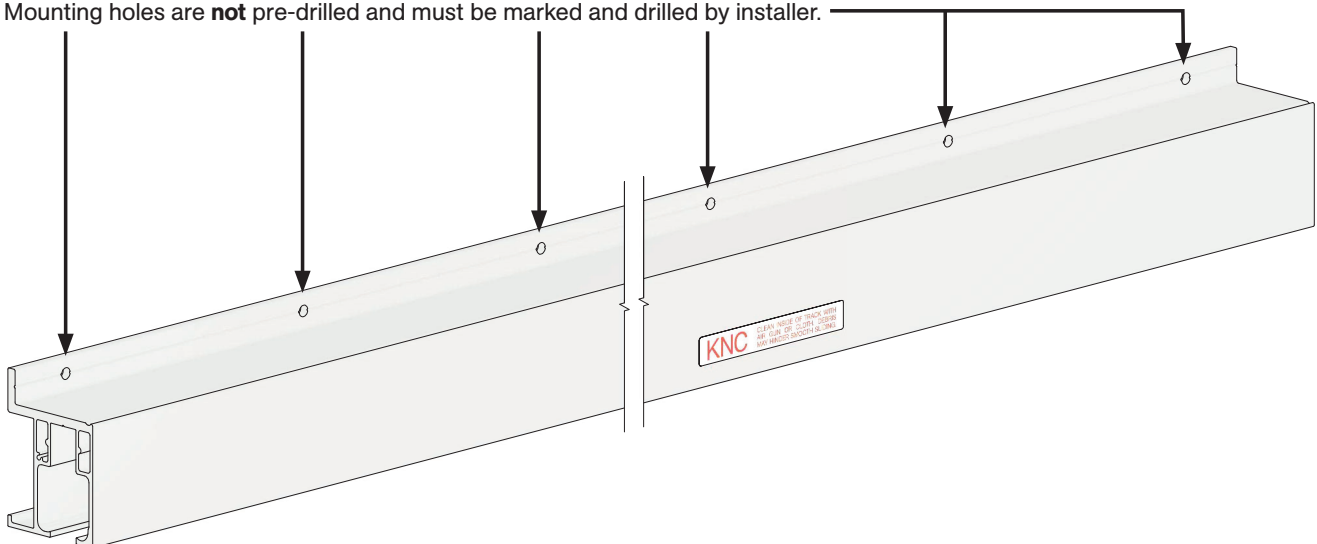

Step #18:

Installing Track

Components required:

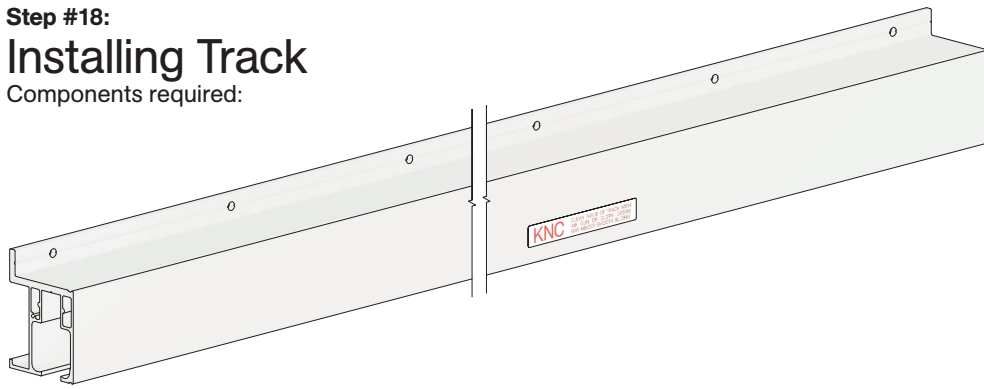

CS-98 Side Mount Track x length (1)



Mounting fasteners by others (X)

Securing Track

Level and secure track to structural support or backing at height as indicated by **TH** (Track height) found on Approved Opening Layout Drawing.

Field Adjustment (If Site Conditions Differ)

If track height is **not** specified or must be recalculated on-site, determine **TH** using following formula:

DH (Door height)

+ 1/2 in [12.7 mm] - bottom guide system clearance

+ 1 3/4 in [44.5 mm] - midpoint adjustment range of top hanger system

= **TH** (Track height, distance from finished floor to underside of CS-98 Track)

Example:

84 in [2134 mm] (**DH**)

+ 1/2 in [12.7 mm]

+ 1 3/4 in [44.5 mm]

= 86 1/4 in [2191 mm] (**TH**)

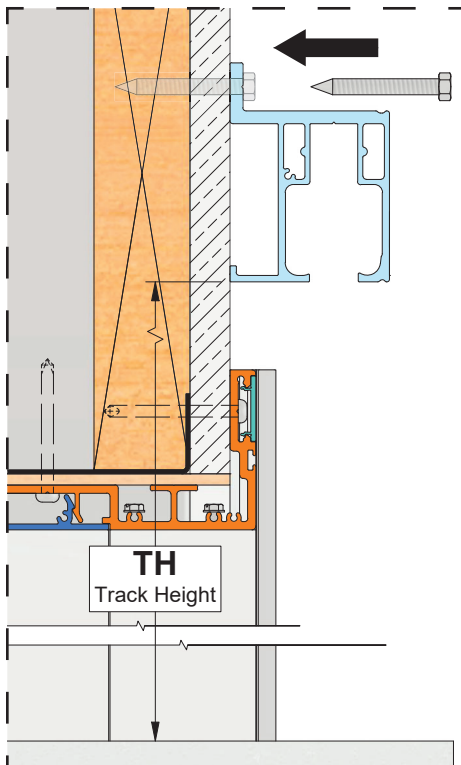

▲ Note for Stops and Hangers

If ends of track will **not** be accessible after track is secured to wall, complete **step #21** on page 52 to insert Stops and Hangers before securing track to wall.

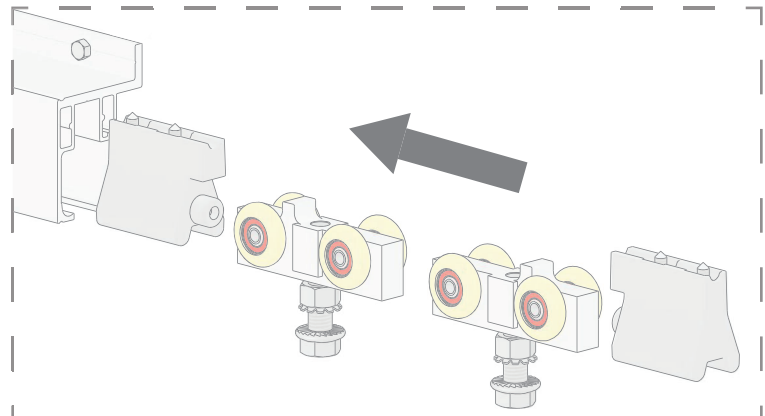

Step #19:

Guide Prep

Components required:

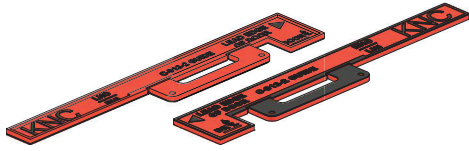

CS-GLT9 Guide Locator Tool (1)

Pre-Install Note: Guide must be installed on finished floor.

Determine Handing

Identify proper side facing up by locating door handing text on both sides of CS-GLT9 Tool.

Check both sides of CS-GLT9 Tool to determine correct orientation based on door handing:

RHO/LHI handing - use side with thick black border

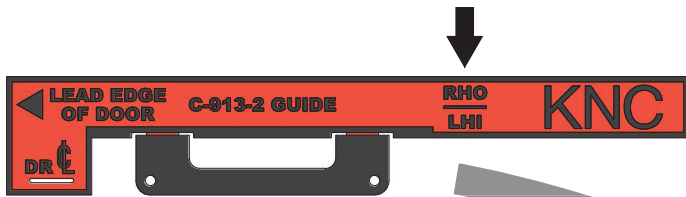

LHO/RHI handing - use opposite side

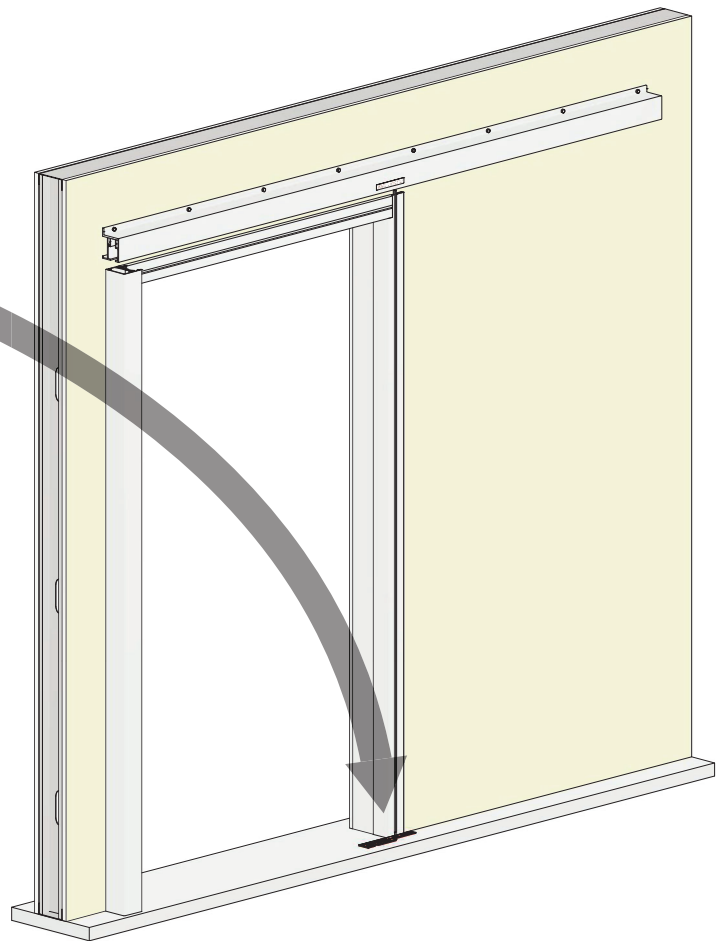
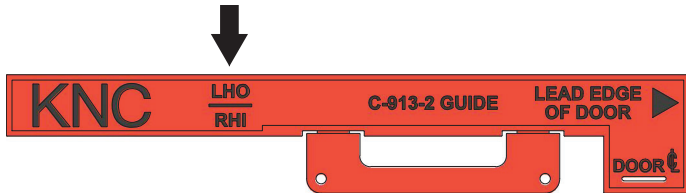

Position CS-GLT9 Tool

Place CS-GLT9 Tool against outside face of **CS-JB** Jamb Base.

Ensure “Lead Edge of Door” text and arrow are pointing toward strike side of opening.

Gently lift gasket to seat tool tight and square against **CS-JB**.

The distance from face of **CS-JB** to lead edge of tool represents required door protrusion (P)—as determined by Approved Opening Layout Drawing.

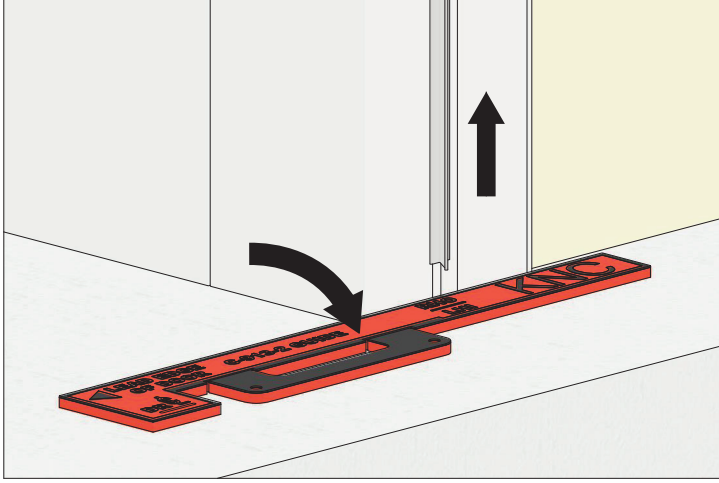

Drill Pilot Holes

Hold CS-GLT9 Tool firmly in place and drill through marked hole locations using it as a template.

Choose drill bit and screws appropriate for your floor type:

Floor Type	Drill Bit Size	Screw Type
Wood	Ø1/8 in [3.2 mm]	#10 x 1-1/2" Flat Head Wood Screws
Concrete	Ø5/32 in [4 mm]	3/16" x 1-3/4" Cement Flat Head Phillips Screws

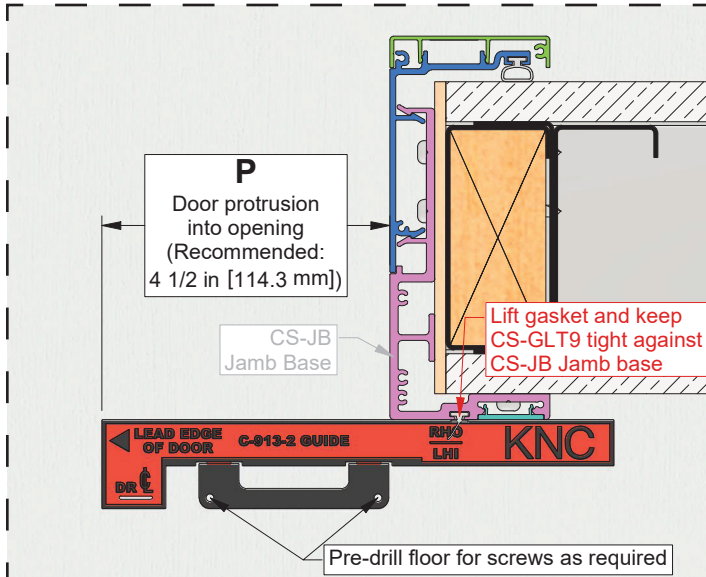

Step #20:

Installing Guide

Components required:

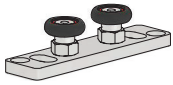

C-913-2 Double Floor Guide (1)



#10 x 1-1/2" Flat Head Screws (4)
[FT7]



3/16" x 1-3/4" Cement Flat Head Phillips Screws w/Grey Ruspert Finish (4)
[STG3]

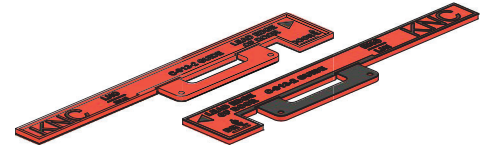

CS-GLT9 Guide Locator Tool (1)

Placing and Pre-Fastening Guide

Carefully break off drill template section from CS-GLT9 Tool.

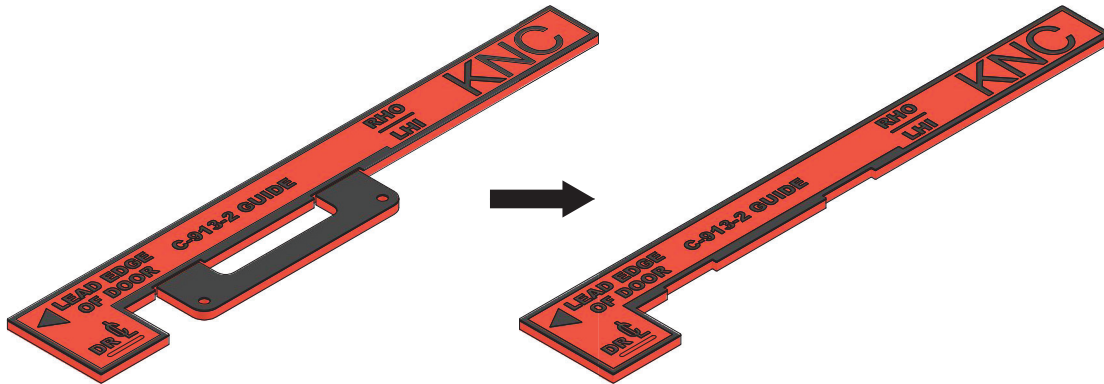

Place remaining portion of tool back in same location as it was in **step #19**, maintaining alignment. Position C-913-2 Guide against tool, aligning oblong holes over pilot holes drilled in previous step. Attach guide loosely using two (2) of supplied screws based on floor type:

Floor Type	Screw Type
Wood	#10 x 1-1/2" Flat Head Wood Screws
Concrete	3/16" x 1-3/4" Cement Flat Head Phillips Screws

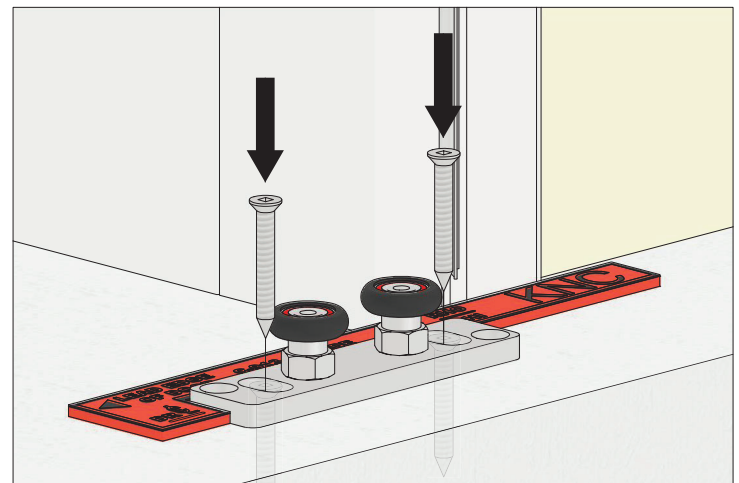
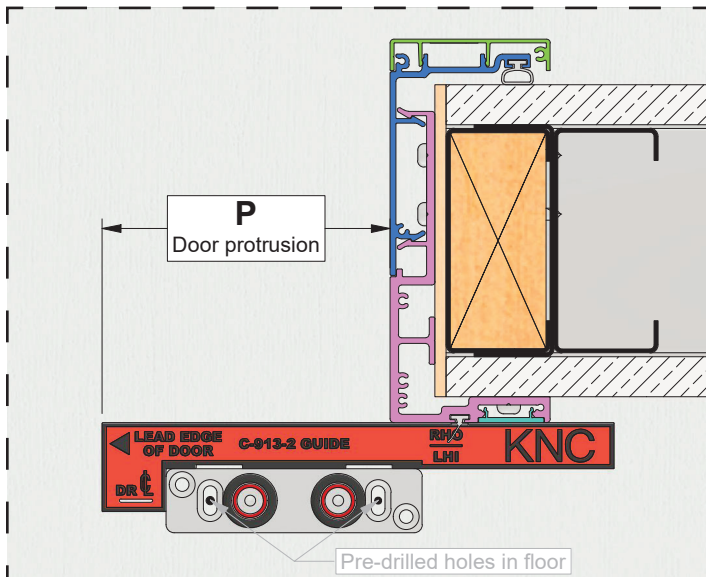
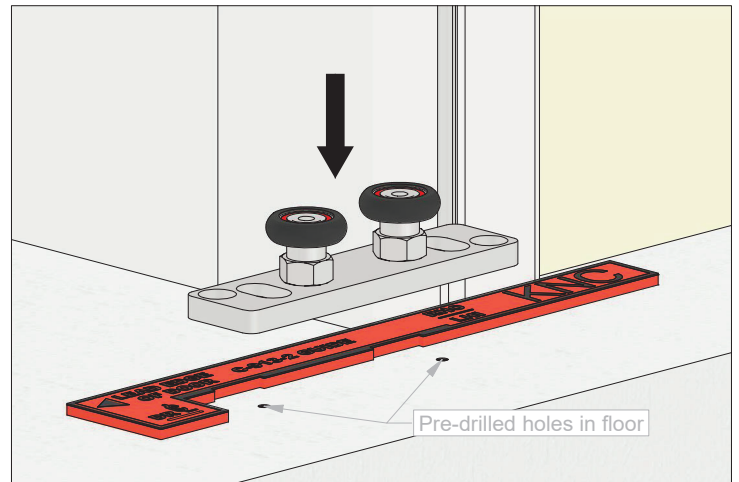

Adjusting Guide

Use oblong holes to fine-tune front-to-back position of guide.

Do **not** overtighten screws until final placement is confirmed.

Final adjustments should be made after door is installed and its plumb is verified.

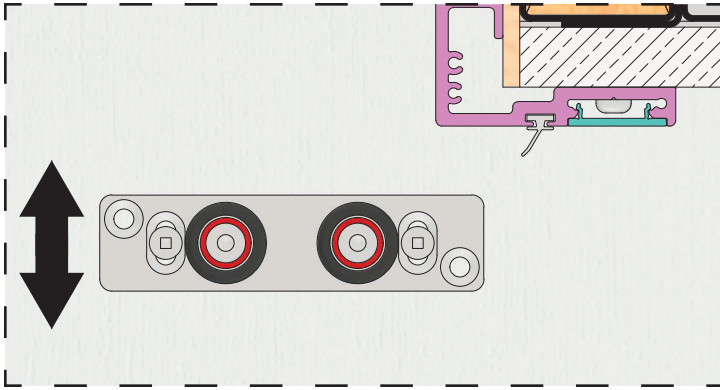

Securing Guide (Complete After Step #22 – Door Installation)

⚠ Note: This step must be completed after step #22 (Hanging Door onto Hangers), once door has been installed and its plumb confirmed.

After verifying door is plumb and all guide adjustments are finalized, temporarily remove door to expose two outer holes in guide.

Pre-drill through these holes into floor.

Install remaining two (2) screws to fully secure guide in place.

This ensures guide is properly anchored and maintains alignment during operation.

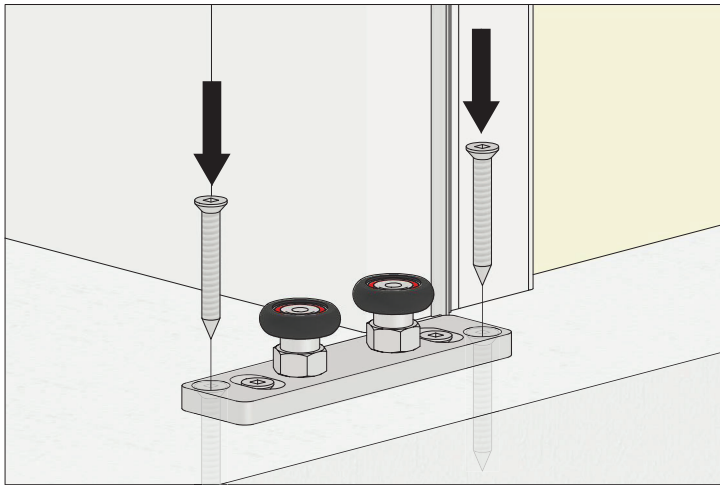

Step #21:

Inserting Stops and Hangers

Components required:

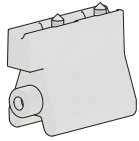

CC-101HD Catch 'N' Close
In-Track Stops (2)

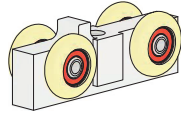

CC-912 Hanger Bodies (2)
c/w wheels

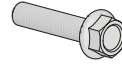

1/2-13 x 2-1/4" Hex
Flange Bolt (2)
[FT34]



1/2-13 K-Lock Nut (2)
[FT33]

Assembling Hangers

Assemble two (2) CC-998 Hangers as shown below:

Fig. 1 Thread a 1/2-13 K-Lock Nut [FT33] onto a 1/2-13 x 2-1/4" Hex Flange Bolt [FT34], with lock washer facing bolt head.

Fig. 2 Thread assembly from **Fig. 1** into CC-912 Hanger Body from underside (side opposite trigger). Do **NOT** fully tighten.

Fig. 3 Final result: Two (2) completed CC-998 Hanger assemblies.

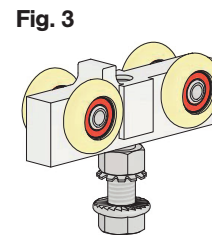
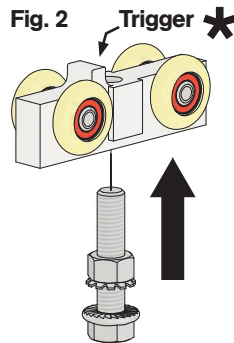
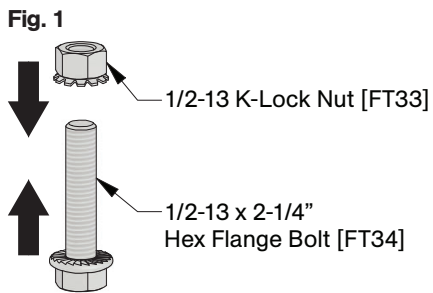

Inserting Hardware into Track

Using either open end of track (right side shown in following illustrations), insert following components in order:

1. CC-101HD Stop, with bumper facing outward.
2. CC-998 Hanger assembly, with trigger (*) end leading.
3. CC-998 Hanger assembly, with trigger (*) end trailing.
4. CC-101HD Stop, with bumper facing inward.

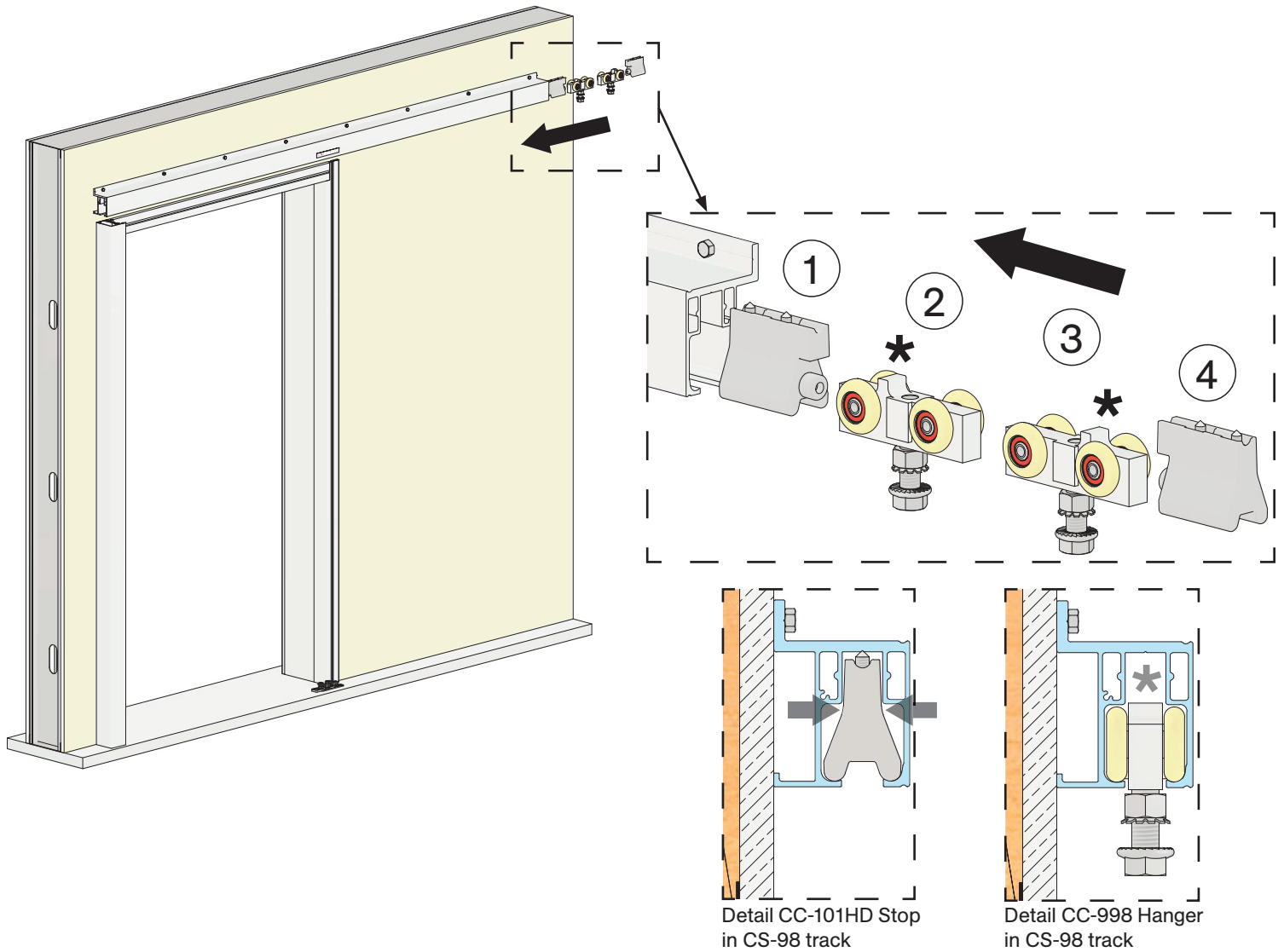

Component Positioning

Place hardware components approximately as shown within track.

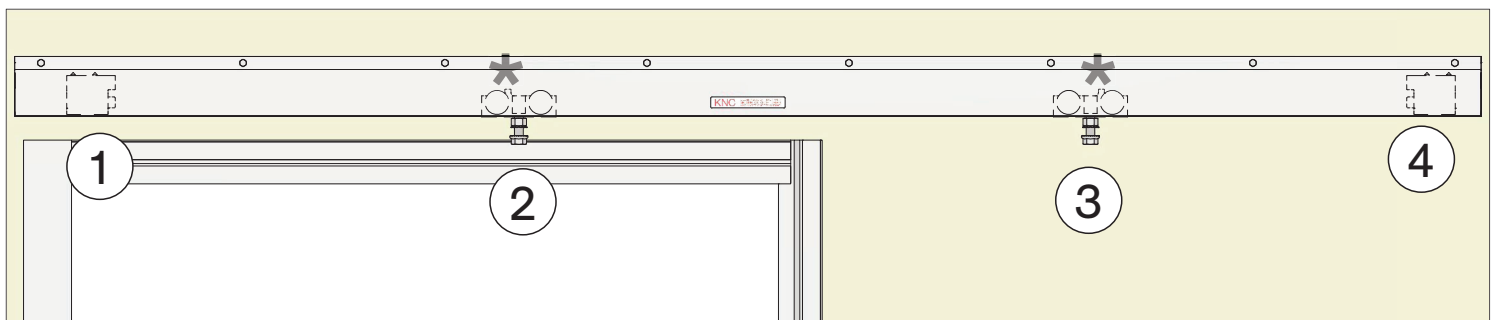

Step #22:

Installing Door

Components required:

Door assembly from steps #15–16

Position Door Over Floor Guide

Raise door assembly with back face oriented toward wall. Carefully lower door over floor guide, ensuring C-913-2 Guide Wheels engage inside C-914 Guide Channel.

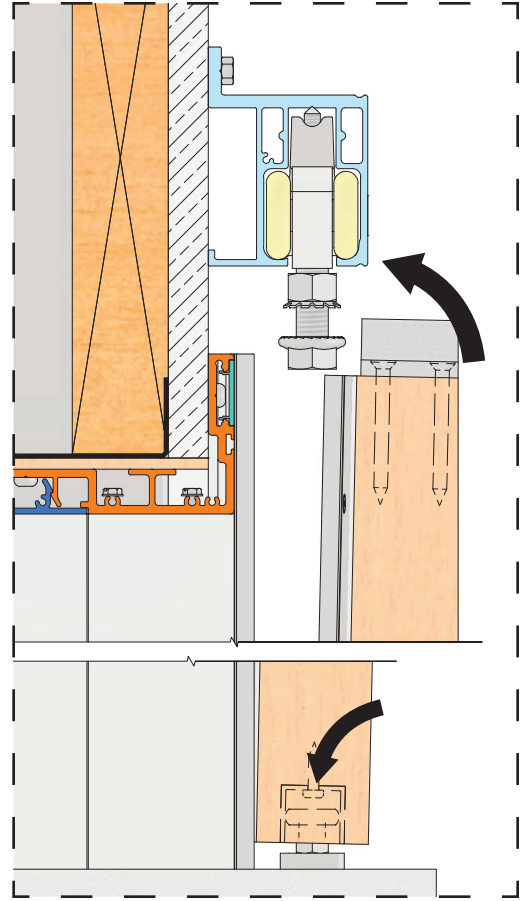
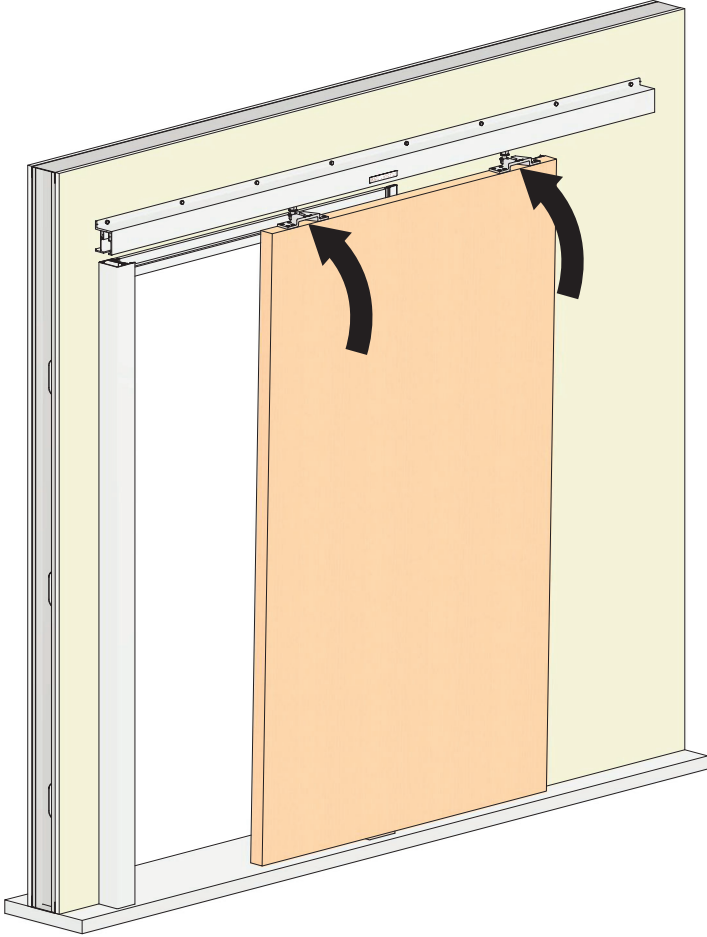

⚠ After verifying door is plumb, see Securing Guide on page 51.

Hanging Door onto Hangers

Align C-998 Top Plates (mounted on top of door) with 1/2-13 x 2-1/4" Hex Flange Bolts [FT34] from hanger assemblies. Guide bolts through U-slots in top plates. Ensure flange heads are fully seated in recessed areas of top plates for secure engagement.

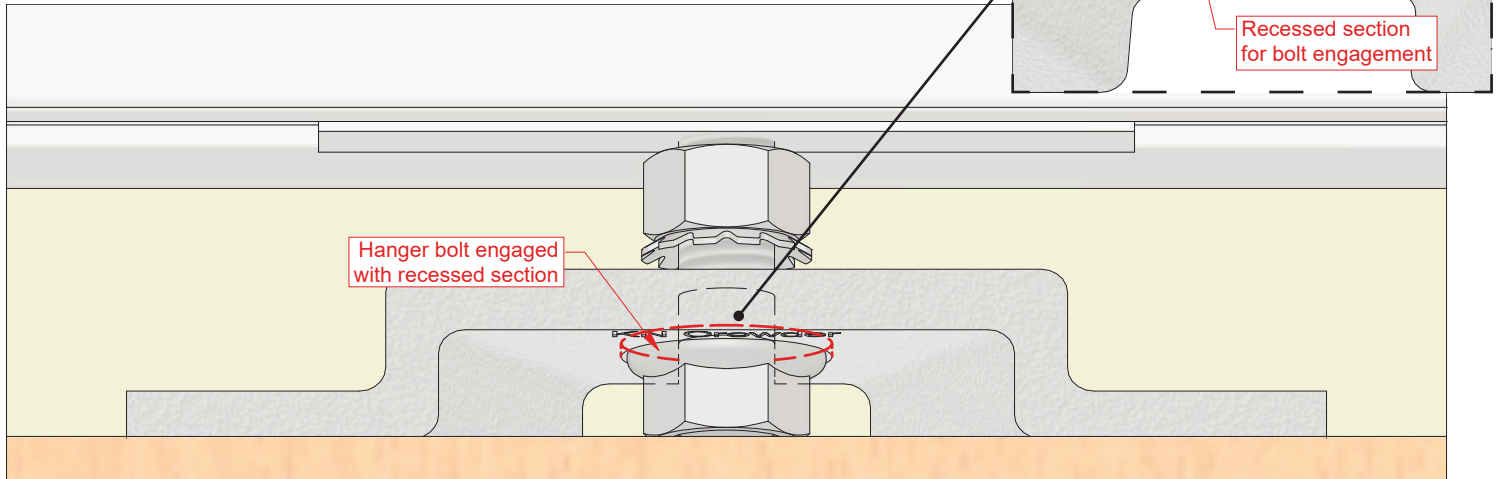

Adjusting Door

Adjust door's height and plumb by turning hex head of hanger bolts using a 3/4 in [19 mm] wrench.

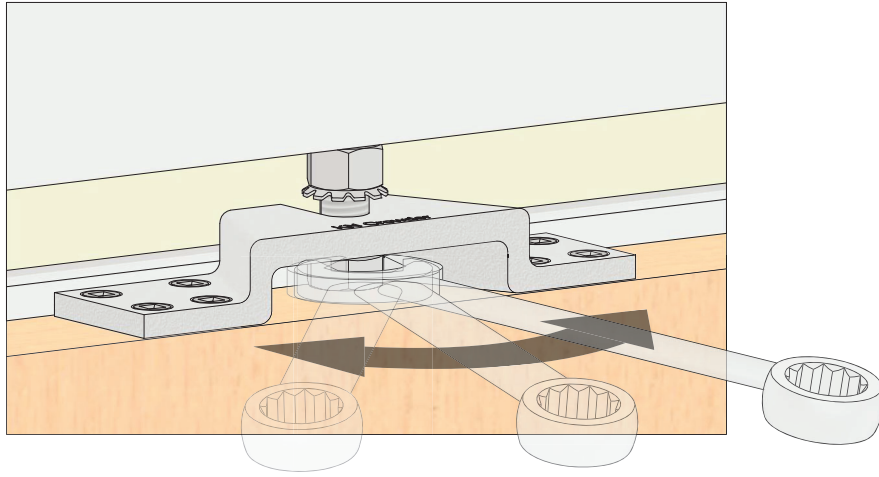

Locking Door Adjustment

Once door is properly positioned, tighten 1/2-13 K-Lock Nuts [FT33] with a second 3/4 in [19 mm] wrench while holding hanger bolts steady to prevent rotation, locking adjustment in place.

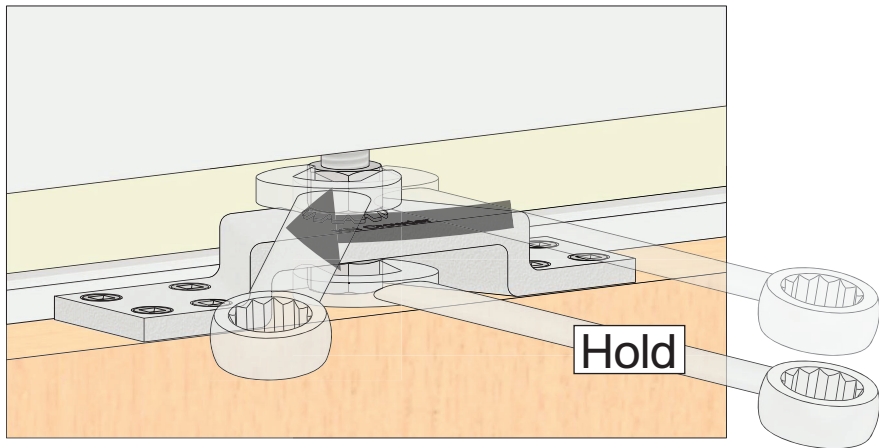

Step #23:

Adjusting Stop for Door in Open Position

Positioning Stop

After door has been installed, position it approximately 5–10 in [120–250 mm] away from its fully open position (as shown right side in illustrations below). Slide loose right-side CC-101HD Stop along within track until its bumper contacts hanger body.

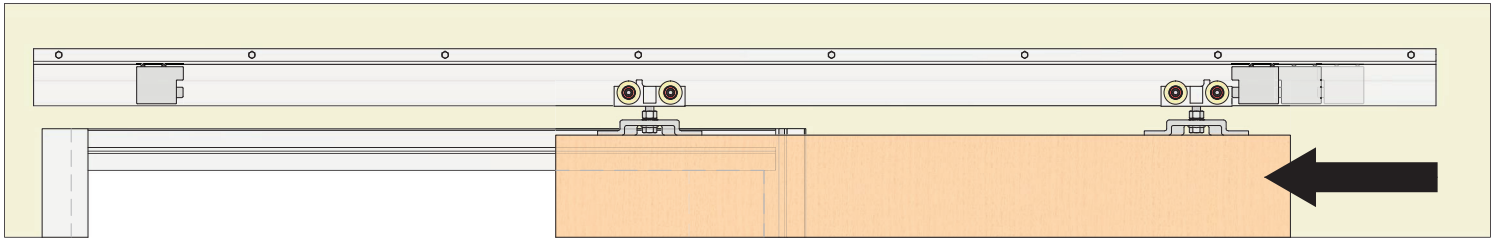

Setting Final Stop Position

With right-side CC-101HD Stop loose, carefully slide door and stop to its fully open (or desired open) position, accounting for required door protrusion as shown in Approved Opening Layout Drawing.

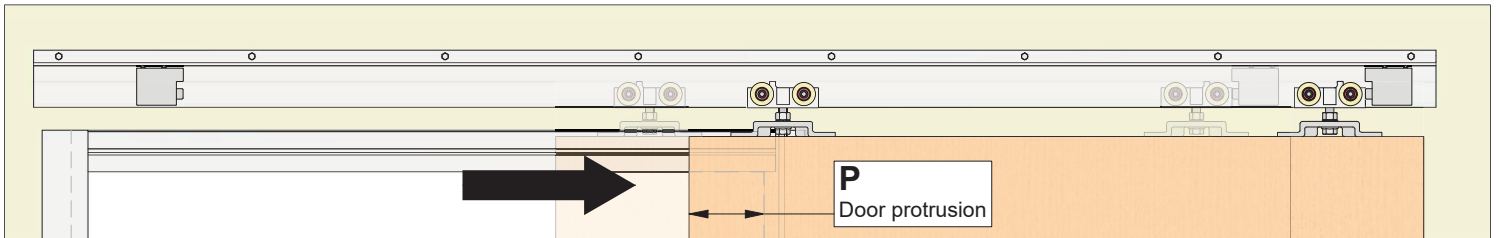

Securing Stop

Carefully slide door away from right-side CC-101HD Stop, taking care not to disturb stop's position. Using a 3/16 in Allen key, tighten one of two cone-point cap screws to hold stop in place. Slide door open to confirm contact with stop and check door's final position. If no further adjustment is needed, tighten second cap screw to fully lock stop in place.

Note: CC-101HD Stops are held securely by a friction fit, as cone point bites into aluminum track.

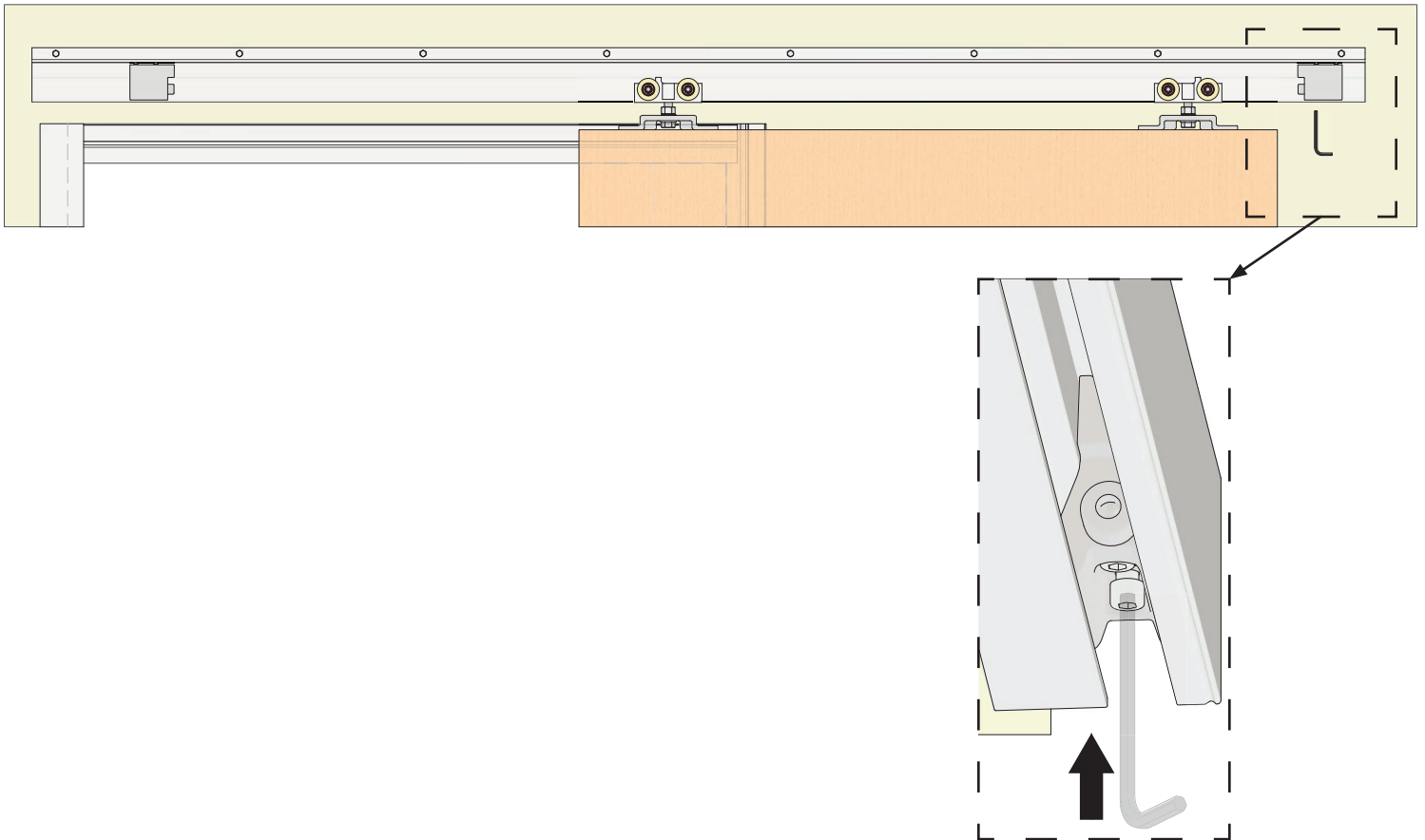

Step #24:

Adjusting Stop for Door in Closed Position

Positioning Stop

Position door approximately 5–10 in [120–250 mm] away from its fully closed position (as shown left side in illustrations below). Slide loose left-side CC-101HD Stop along within track until its bumper contacts hanger body.

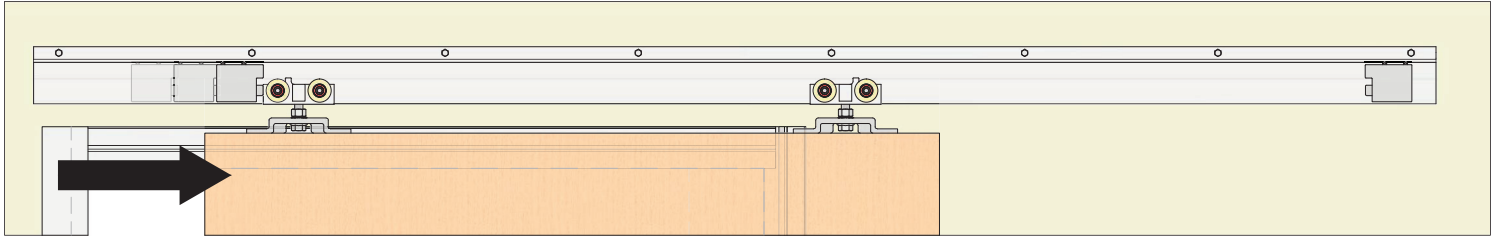

Setting Final Stop Position

With left-side CC-101HD Stop loose, carefully slide door to its fully closed (or desired closed) position. Ensure leading edge of door makes full contact with **CS-SC** Strike Cover's strike channel, compressing strike gaskets as intended (see Detail A).

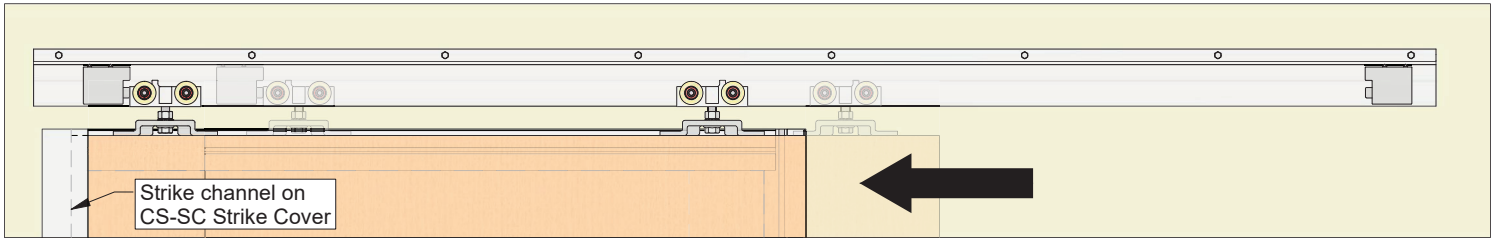

Securing Stop

Carefully slide door away from left-side CC-101HD Stop, taking care not to disturb stop's position. Using a 3/16 in Allen key, tighten one of two cone-point cap screws to hold stop in place. Slide door closed to confirm full contact with the strike cover and gasket compression. If no further adjustment is needed, tighten second cap screw to fully lock stop in place.

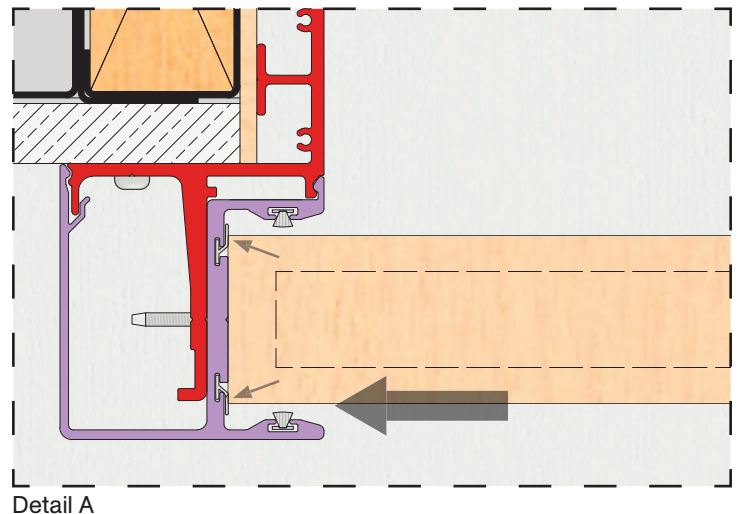
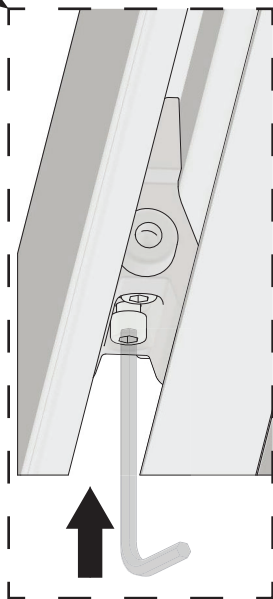
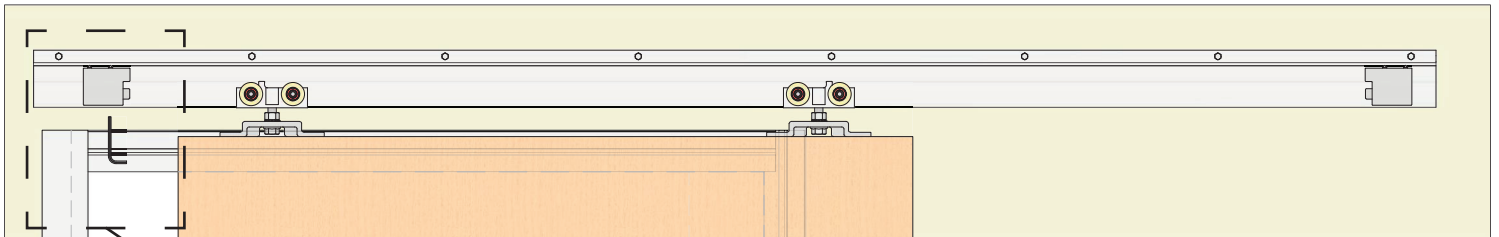

Step #25:

Installing Catch 'N' Close for Closed Position

Components required:

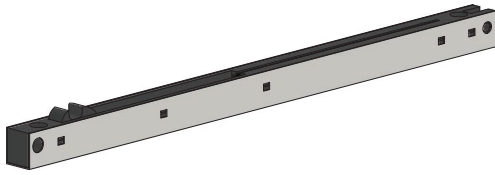

Catch 'N' Close (1)



**#10 x 1-1/2" Self-Drilling
Screws (2)
[FT5]**

Review Catch 'N' Close

Before installation, ensure each Catch 'N' Close Device is in retracted position, as shown. If hook is **not** in retracted position, press it towards End 'B' until it locks into place— this may require significant finger pressure. Identify End 'A' and End 'B' for correct orientation during installation.

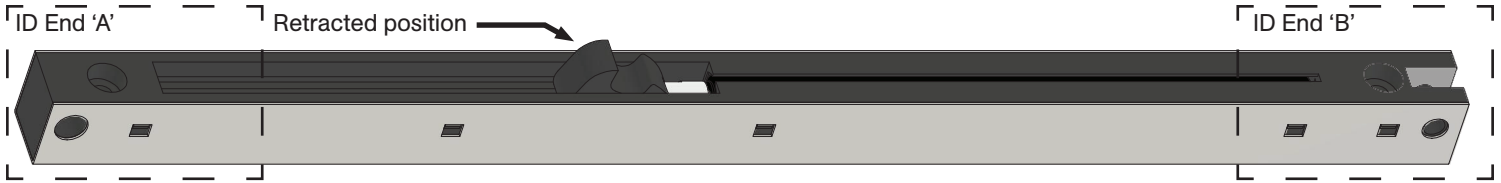

Device Selection Notes:
For doors 200 lbs [91 kg] or less, use CC-2 Catch 'N' Close Devices.
For doors 200–300 lbs [91–136 kg], use CC-3 Catch 'N' Close Devices.

Position Device

With door in fully open position, insert one Catch 'N' Close Device into track, ensuring End 'A' is positioned firmly against upper body of CC-101HD Stop.

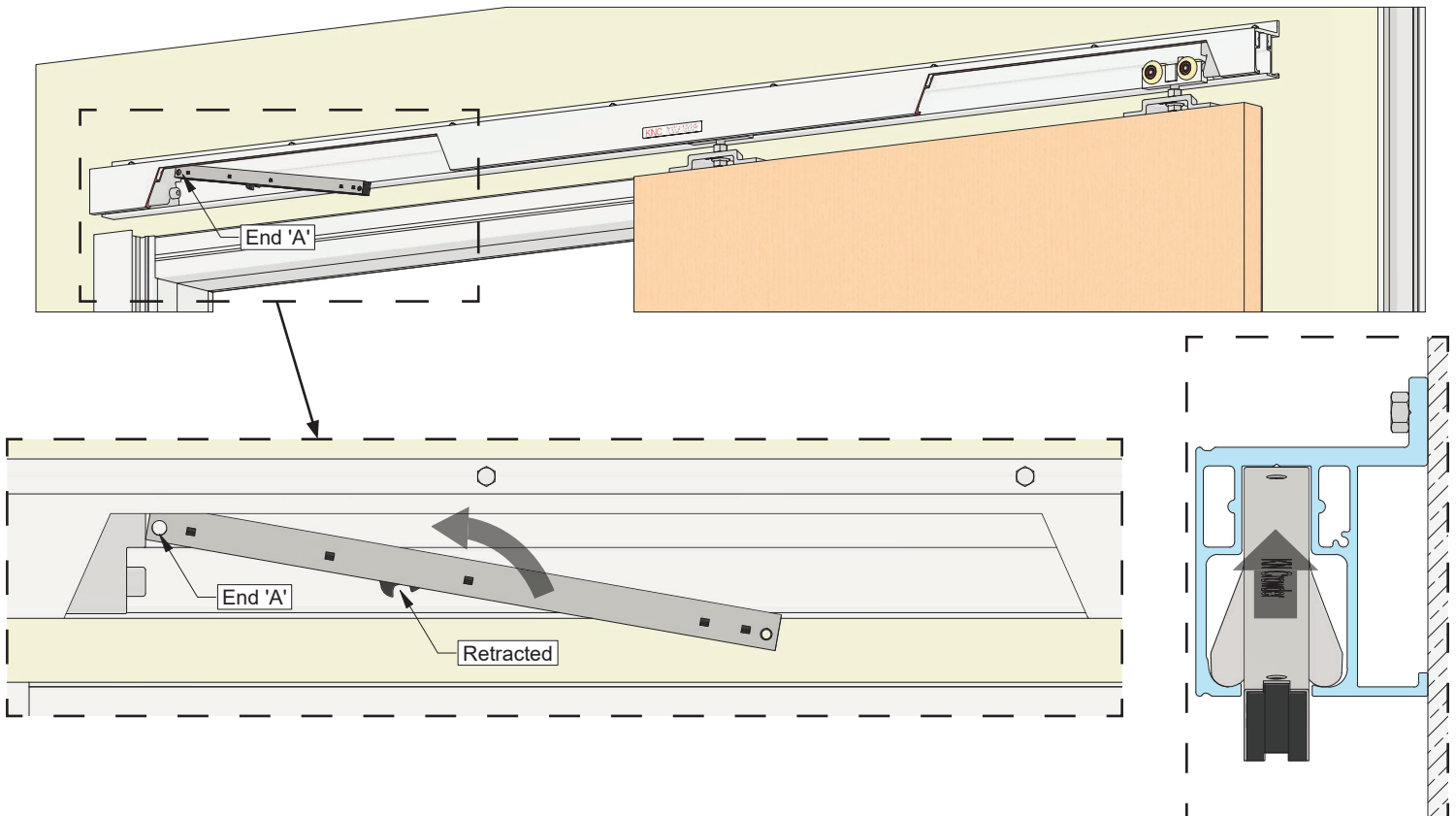

Securing Device

1. Pre-drill two (2) $\text{\O}9/64$ in [3.6 mm] pilot holes to facilitate easier alignment and screw installation.
2. Install first screw, located closest to CC-101HD Stop. If using an impact driver, avoid over-tightening to prevent damage.
3. Remove any metal shavings from track.
4. Slide door closed to test system engagement.
5. If properly positioned, install second screw to fully secure device.

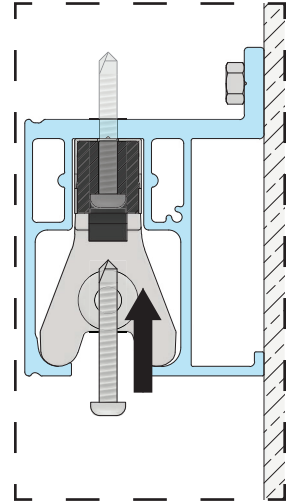
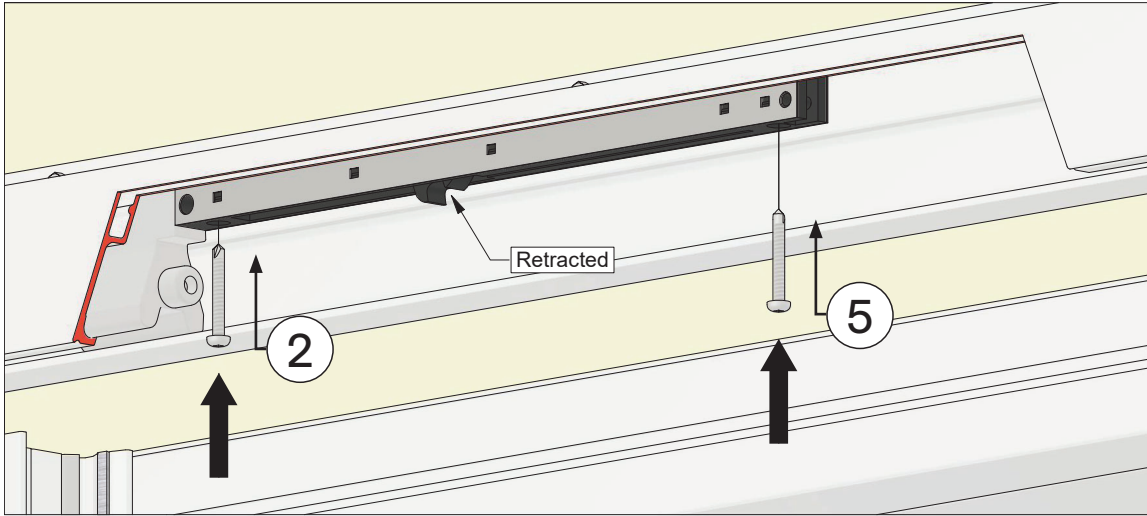

Step #26:

Installing Catch 'N' Close for Open Position

Components required:



Catch 'N' Close (1)



#10 x 1-1/2" Self-Drilling
Screws (2)
[FT5]

Review Catch 'N' Close

Before installation, ensure each Catch 'N' Close Device is in retracted position, as shown. If hook is **not** in retracted position, press it towards End 'B' until it locks into place— this may require significant finger pressure. Identify End 'A' and End 'B' for correct orientation during installation.

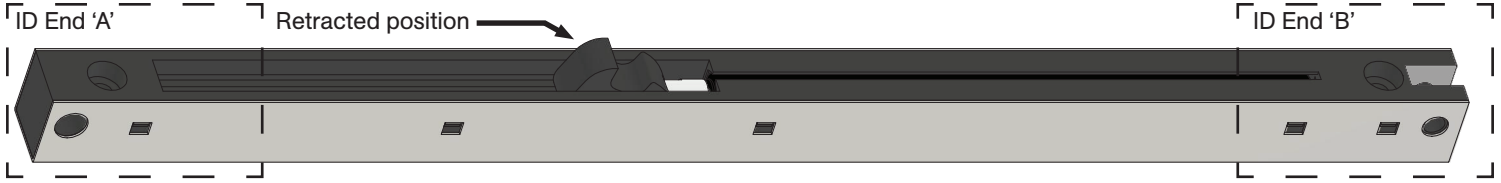

Device Selection Notes:
For doors 200 lbs [91 kg] or less, use CC-2 Catch 'N' Close Devices.
For doors 200–300 lbs [91–136 kg], use CC-3 Catch 'N' Close Devices.

Position Device

With door in fully closed position, insert second Catch 'N' Close Device into track, ensuring End 'A' is positioned firmly against upper body of CC-101HD Stop.

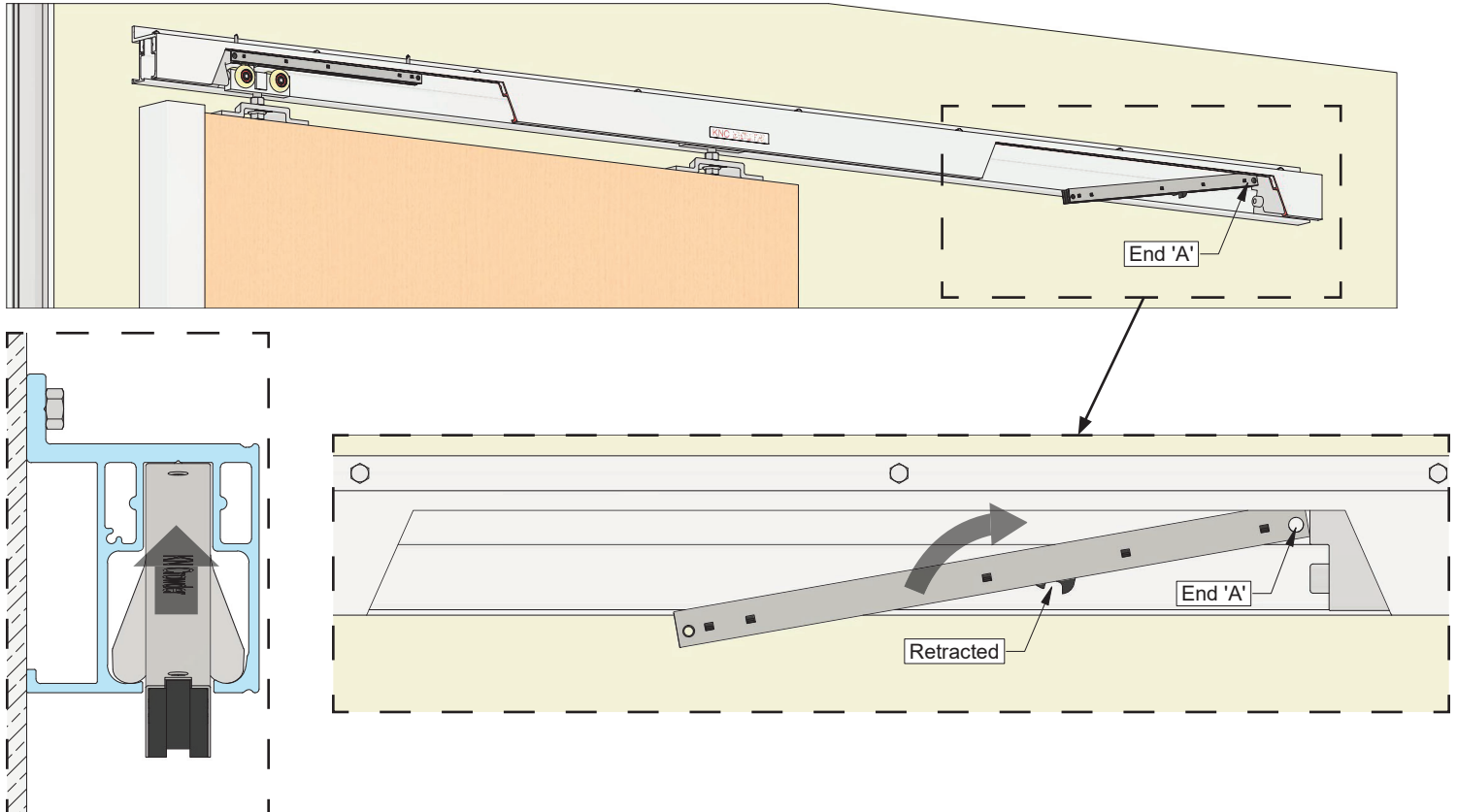

Securing Device

1. Pre-drill two (2) $\text{Ø}9/64$ in [3.6 mm] pilot holes to facilitate easier alignment and screw installation
2. Install first screw, located closest to CC-101HD Stop. If using an impact driver, avoid over-tightening to prevent damage.
3. Remove any metal shavings from the track.
4. Slide door open to test system engagement.
5. If properly positioned, install second screw to fully secure device.

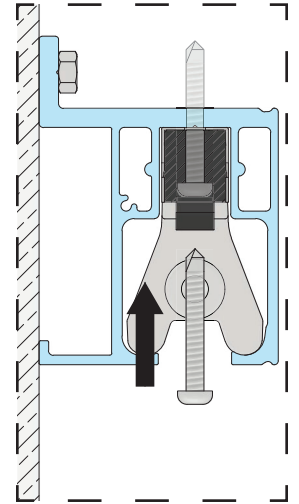
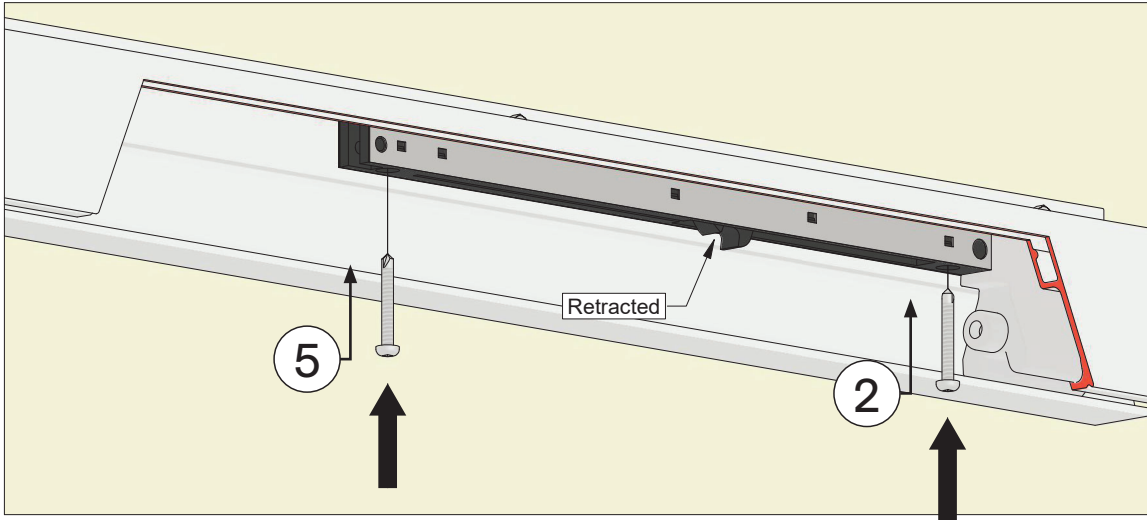

Step #27:

Installing Fascia

Components required:

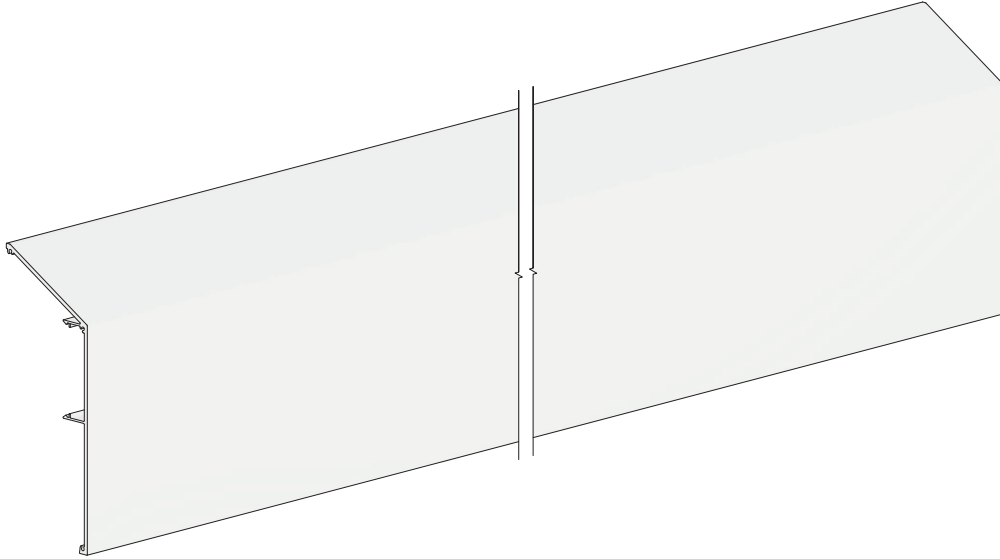

CS-99 Snap-on Fascia x length (1)

Preparing Fascia

Fascia length is supplied as specified in Approved Opening Layout Drawing, unless scribe was ordered. If trimming is necessary, cut fascia to match installed length of CS-98 track.

Installing Fascia

Lift Fascia up to track. Snap it into place as shown.

If fascia feels loose, use a rubber mallet to gently tap inside legs at 24 in [600 mm] intervals to tighten fit.

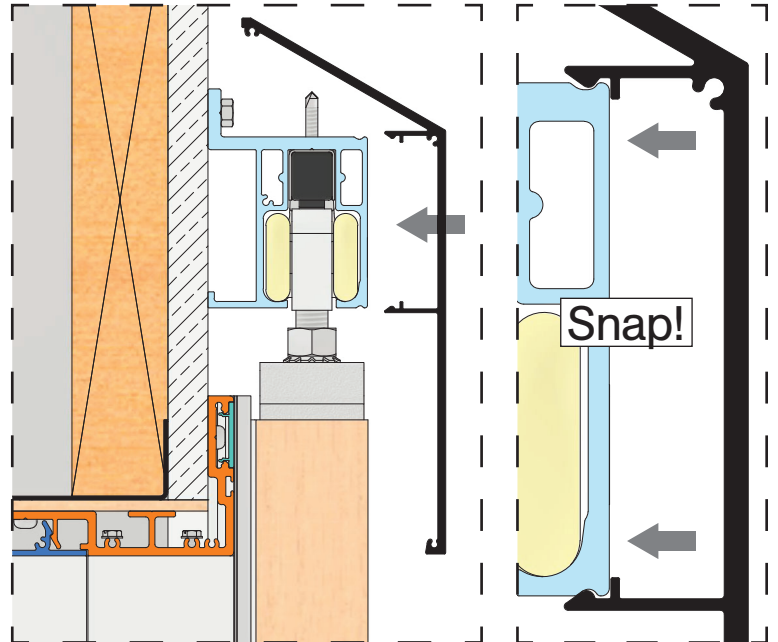
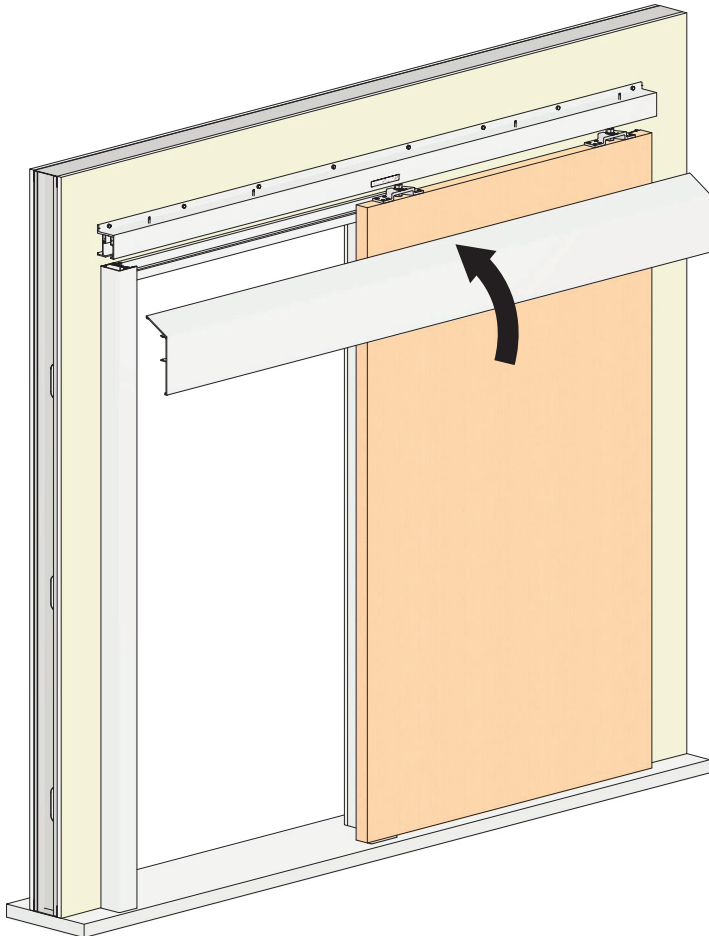

Step #28:

Installing Fascia End Caps

Components required:

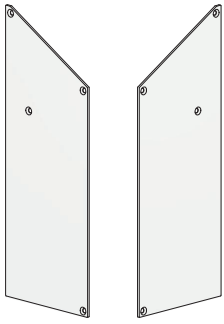

CS-9 End Caps (2)
Left and right

#4 x 5/16" Flat Head Screws (8)
[FT29]

Installing End Caps

Install end caps as shown using supplied screws.

Note: Do not install with impact driver.

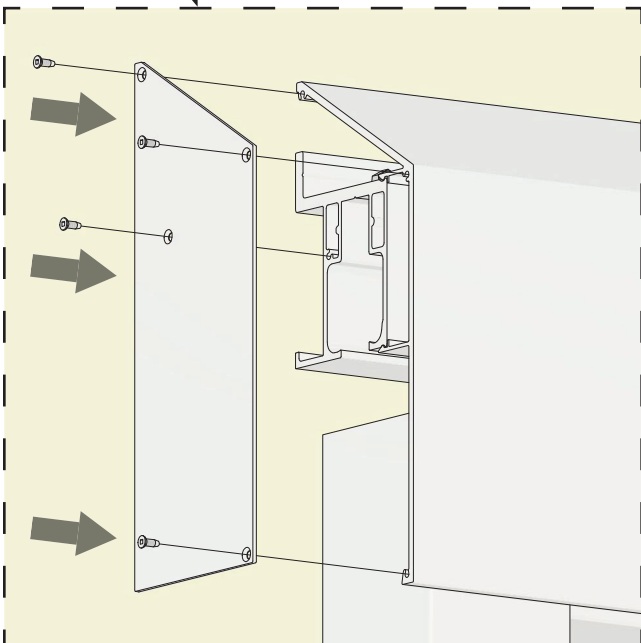
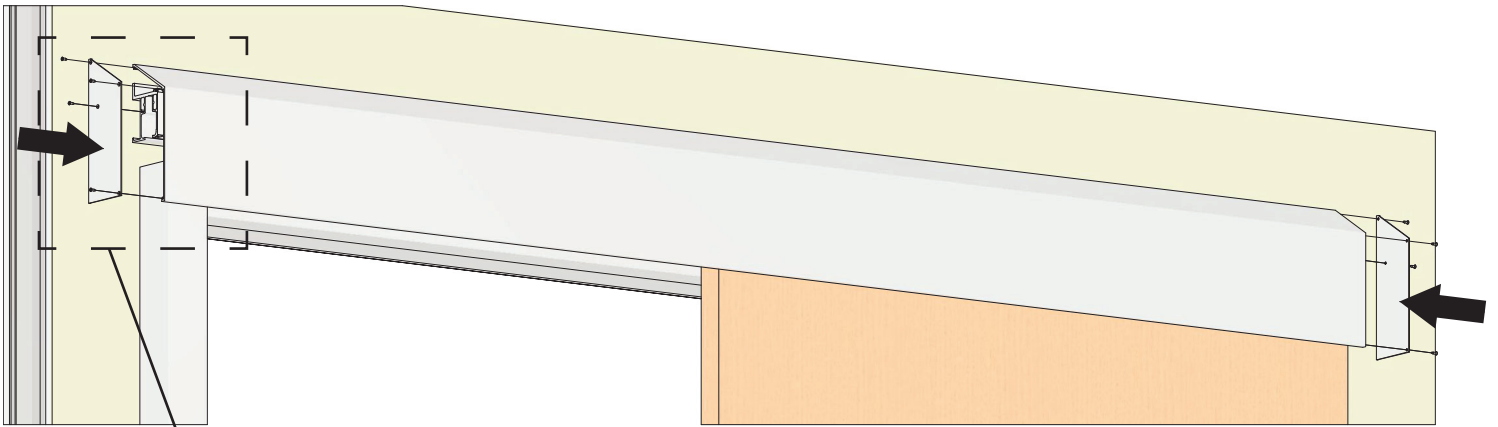

Troubleshooting

Issue	Solution
Gaps at joints	When cutting covers or parts, ensure accurate cuts for a snug fit as outlined in the installation steps. This limits visible gaps at joints. If parts are cut too short, contact your KN Crowder distributor for replacements.
Chatter or noise when door is sliding	Check for aluminum shavings inside track. These can embed in nylon wheels and cause noise during operation.
Door is hard to move	<ul style="list-style-type: none">• Ensure floor guide is positioned far enough from the wall to allow clearance for gaskets.• Ensure guide channel at the bottom of door is not overtightened, as this can pinch the guide and restrict movement. If overtightening is suspected, remove door and slide guide inside channel to check for smooth travel - there should be little to no resistance. If needed, loosen screws slightly on either side of guide channel, then recheck for smooth sliding before reinstalling door.• Confirm the door is not dragging on floor. If it is, adjust door height as needed to eliminate contact.
Door rattles	Check all locking nuts and screws on hangers are tightened and secure.
Door is not engaging Catch 'N' Close device	<ul style="list-style-type: none">• Confirm CC-998 Hangers are correctly oriented (see step #21).• Ensure the Catch 'N' Close device is in the extended (engaged) position before sliding the door toward it. If the hook is still retracted, the door will bypass the device and fail to engage.
Replacing the Catch 'N' Close Device	The Catch 'N' Close system is designed for easy replacement. If a device fails, remove the two screws securing it and replace with a new device.
Replacing gasket inserts	Slide out existing jamb gasket inserts and replace with new ones. Some gaskets may require door removal and CS-SC Strike Cover removal for access. Note: CS-AFB Angled Flat Bar gaskets are peened into place and cannot be removed. Replacing them requires purchasing a new CS-AFB with gasket pre-installed.

Superior design & quality: KN Crowder is committed to innovation and producing quality engineered, durable, time-tested sliding door hardware. Our engineering experts provide solutions to your specific hardware needs. Our raw materials are of the highest quality and North American sourced, with all manufacturing done in Canada. With over 150,000 cycle tests or the equivalent of 30 years of use, our hangers stand strong without experiencing any measurable wear or increase in noise.