

# CT-50 & CT-52 AUTOMATIC DOOR BOTTOMS

INSTALLATION  
INSTRUCTIONS



## SURFACE OR SEMI-MORTISED MOUNTING AUTOMATIC DOOR BOTTOMS

### REGULAR DUTY

### HEAVY DUTY

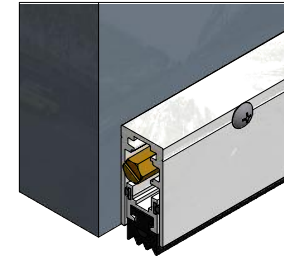
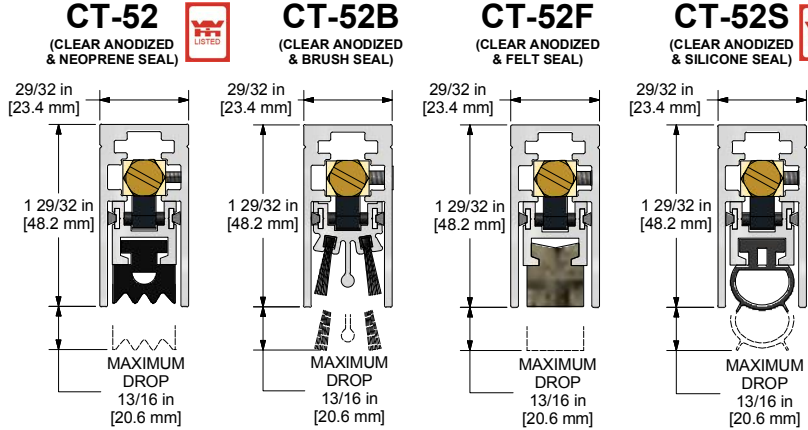
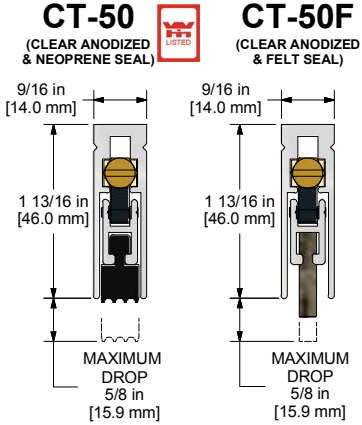

**SURFACE MOUNTED:**  
FITS BETWEEN STOPS.  
(ALLOW 1/16" CLEARANCE  
AT BOTH ENDS BETWEEN  
HOUSING AND STOP).

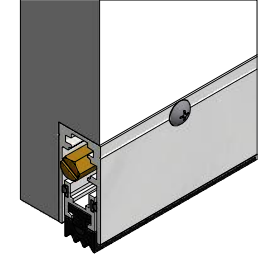

**SEMI-MORTISED:**  
CUT TO FULL WIDTH  
OF THE DOOR.

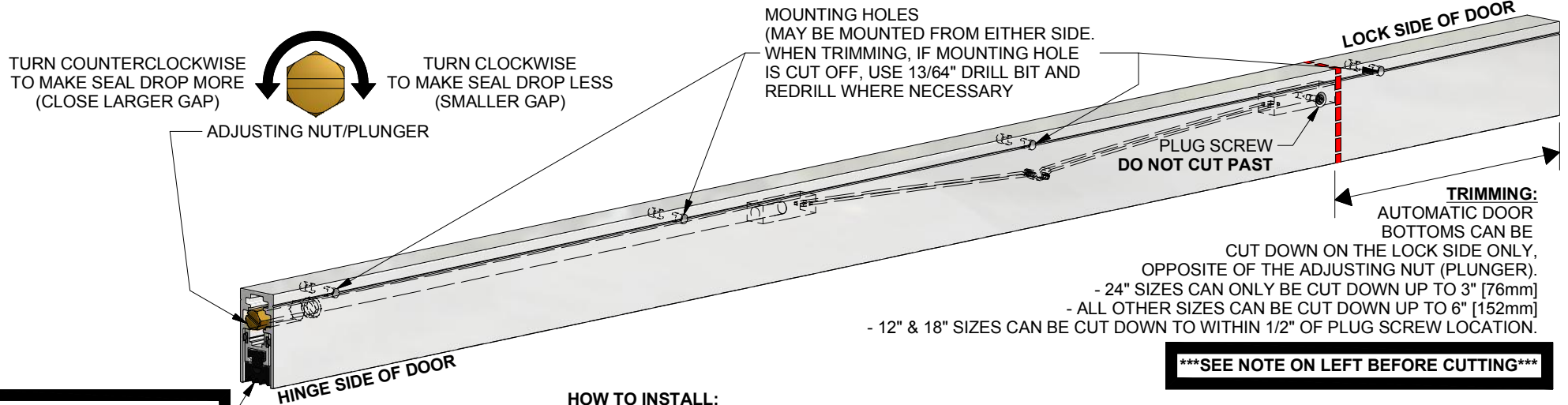

**NOTE: PRESSURE PLATE MOVES Laterally APPROXIMATELY 1/4". ENSURE THAT THE PRESSURE PLATE IS EXTENDED FULLY TO THE LOCK SIDE, BEFORE TRIMMING**

### HOW TO INSTALL:

FOR SEMI-MORTISED APPLICATIONS, DOORS MUST BE PREPARED IN ADVANCE. SEE DIMENSIONS AND NOTES ABOVE FOR PROPER CUT-OUT DIMENSIONS. SEE ABOVE RIGHT FOR THE AUTOMATIC DOOR BOTTOM LENGTHS BASED ON MOUNTING APPLICATIONS.

ALL SURFACE AND SEMI-MORTISED AUTOMATIC DOOR BOTTOMS MUST BE MOUNTED ON THE PUSH SIDE OF THE DOOR (SIDE WHERE THE DOOR STOP IS).

THE ADJUSTING NUT/PLUNGER MUST BE INSTALLED ON THE HINGE SIDE OF THE DOOR FOR ALL MOUNTING APPLICATIONS.

### FINAL ADJUSTMENT:

TURN ADJUSTING NUT COUNTERCLOCKWISE OR CLOCKWISE, AS PER ABOVE LEFT, TO ENSURE SEAL MAKES CONTACT WITH SILL/FLOOR. A FULLY COMPRESSED SEAL IS NOT RECOMMENDED, NOR IS IT NECESSARY AND WILL INHIBIT PROPER OPERATION. SEAL SHOULD SIMPLY MAKE CONTACT WITH SILL/FLOOR.

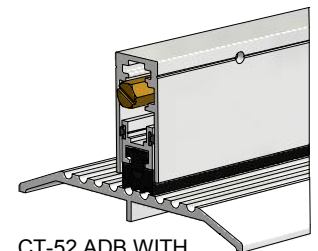

CT-52 ADB WITH CT-10 THRESHOLD



**K.N. CROWDER MFG. INC.**  
1220 BURLOAK DRIVE  
BURLINGTON, ONTARIO, CANADA, L7L 6B3  
TELEPHONE: 905-315-9788 - FAX: 905-315-8090  
TOLL FREE PHONE: 1-866-999-1KNC (1562)  
TOLL FREE FAX: 1-800-567-0123

WEBSITE: [www.kncrowder.com](http://www.kncrowder.com) --- E-MAIL: [customerservice@kncrowder.com](mailto:customerservice@kncrowder.com)