

# CT-707 NEW



# KNC

OPTSTD

## FINISHES

- Mill Finish
- Special \_\_\_\_\_

## SCREW OPTIONS

Standard

-  Screw Type: G  
3/16" X 1-3/4" Hi-Lo Tapping Thread, Grey  
Phillips/Robertson Combo Drive, Concrete Screws  
(5/32" pre-drill required)

Optional

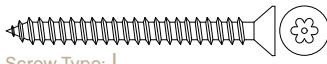
-  Screw Type: H  
#10 X 1-3/4" Stainless Steel Flat Head, Robertson  
Drive, Type A Screws  
(complete with nylon anchor)
-  Screw Type: I  
#10 X 2" Stainless Steel Flat Head,  
Tamper-Resistant Torx Drive, Type A Screws  
(complete with nylon anchor)



**Operation:** Threshold  
**Features:** Mill Finish Extruded Aluminum  
**Application:** Ideal for Residential, Commercial & Industrial  
**Maximum Length:** 156 in [3962 mm]

Customer Name \_\_\_\_\_ Job No./Name \_\_\_\_\_ Date \_\_\_\_\_ Provided By \_\_\_\_\_

Notes

# KN Crowder

1220 Burloak Drive, Burlington, Ontario, Canada, L7L 6B3  
T. 1-866-999-1562 customerservice@kncrowder.com kncrowder.com  
© 2020-2025 K.N. Crowder Mfg. Inc. All Rights Reserved.