

TYPE C

KNC



FEATURES

- 150 lbs. [68 kg] weight capacity
- For doors wider than 18 in [457 mm]
- Quick Release Hanger System for quick and easy installation
- Nylon wheels and precision ball bearings provide smooth and quiet door operation
- Crowder Frame pocket door kit including header track, header brackets, steel uprights and foot brackets to build a pocket on site
- Cycle tested for up to 150,000 cycles without fail
- ADA Compliant (Barrier-free) design

COMPLETE 1 DOOR KIT BREAKDOWN



Each kit includes one CP-803 Header Track x length based on kit size, two CP-HB2X4 Header Brackets, two CP-830 Drywall Support x length based on kit size, four (or six) Steel Uprights x length based on kit size, two (or three) CP-2X4 Foot Brackets, two C-411 Quick Release Hangers, two CDC-411 Catch/Stops, set of C-1200 Guides and necessary fasteners

OPTIONAL

Door Locks & Pulls



Add-On Products



CPD-2X4-Joiner Kit

Use for applications where double bi-parting door openings are required. Two single Crowder Frame kits are required in order to use the joiner kit.

Door Width

18 in [457 mm] to 36 in [914 mm] wide

Greater than 36 in [914 mm] to 48 in [1219 mm] wide

Door Height

80 in [2032 mm] to 84 in [2134 mm]
or 2150 mm high

92 in [2337 mm] to 96 in [2438 mm]
or 2455 mm high

Customer Name

Job No./Name

Date

Provided By

Notes

KN Crowder

1220 Burloak Drive, Burlington, Ontario, Canada, L7L 6B3
T. 1-866-999-1562 customerservice@kncrowder.com
© 2020-2023 K.N. Crowder Mfg. Inc. All Rights Reserved.

kncrowder.com

TYPE C

KNC

COMPLETE ELEVATION VIEW

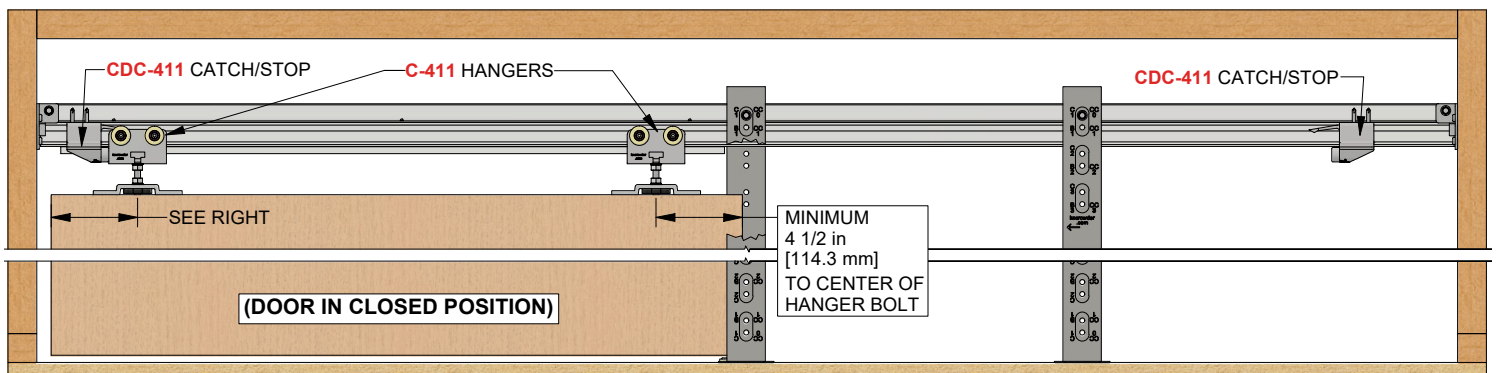
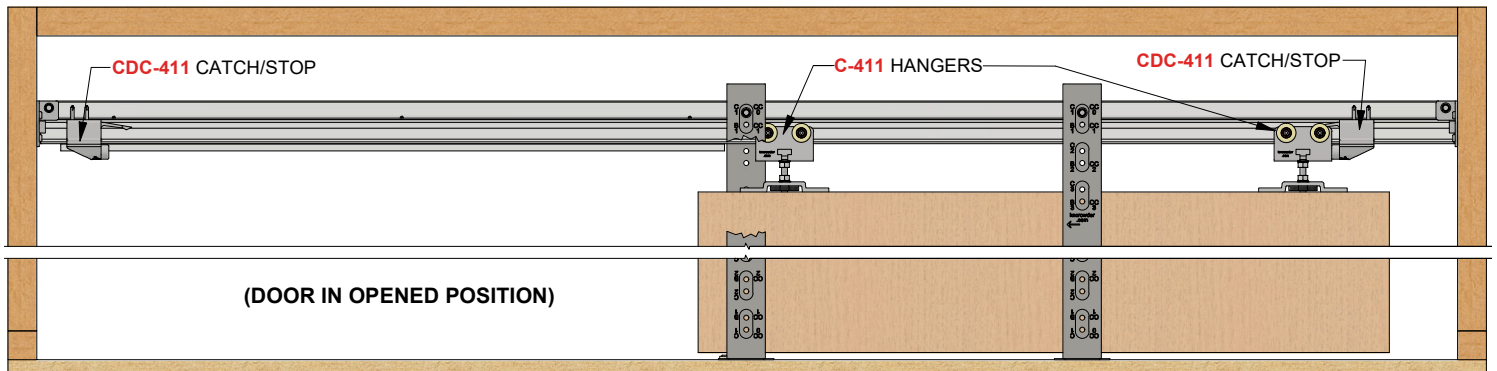

Customer Name

Job No./Name

Date

Provided By

Notes

KN Crowder

1220 Burloak Drive, Burlington, Ontario, Canada, L7L 6B3
T. 1-866-999-1562 customerservice@kncrowder.com
© 2020-2023 K.N. Crowder Mfg. Inc. All Rights Reserved.

kncrowder.com

TYPE C



PRODUCT DIMENSIONS

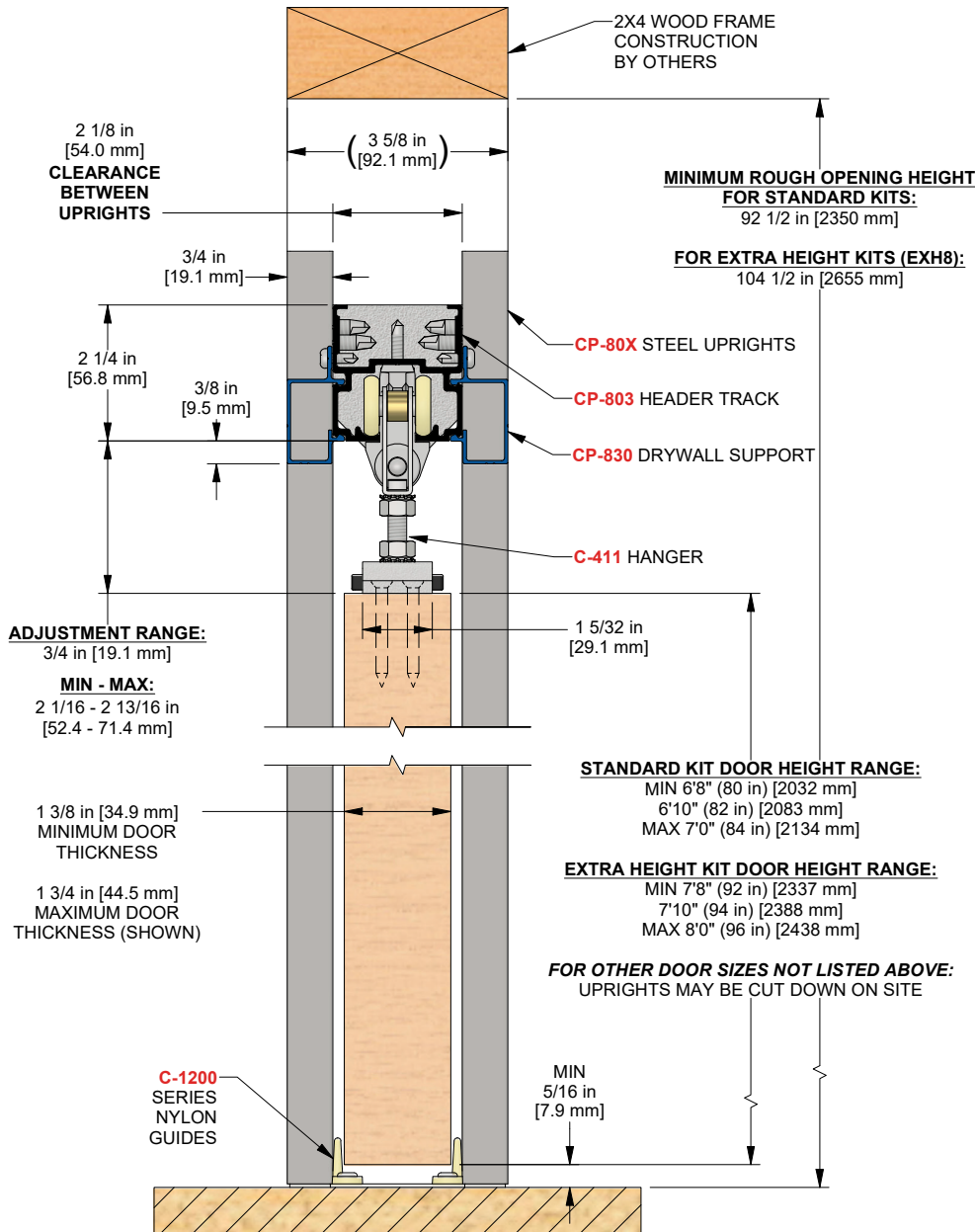

Installation
Instructions



Customer Name

Job No./Name

Date

Provided By

Notes