

Type C-W-2X6

Installation Instructions

For doors 18 in [457 mm] to 48 in [1219 mm] wide

KNC

Crowder Frame System

- Crowder Frame is a complete pocket door kit system that includes roll-formed steel uprights, to build the pocket for 2X6 wall construction
- The complete Crowder Frame kit provides quicker and easier installation than a traditional pocket built on-site
- Cycle tested up to 150,000 times
- Up to 150 lbs. [68 kg] doors
- This installation instructions is suitable for doors 18 in [457 mm] to 48 in [1219 mm] wide and 78 in [1981 mm] to 120 in [3048 mm] high and 1 3/8 in [34.9 mm] to 2 1/2 in [63.5 mm] thick
- For double/bi-parting doors, use two single door kits with **CPD-2X6-Joiner Kit** accordingly, refer to installation instructions **CPD-2X6-Joiner Kit**
- Complete with **C-914** Guide Channel & **CP-913** Pocket Guide system
- It is strongly recommended to use edge pulls or door locks with integrated edge pulls and flush pulls for easy operation of pocket doors, visit <http://www.kncrowder.com/doorlocks-pulls/> for options
- KN Crowder recommends: **C-90L-ET** privacy lockset, **C-90L-CT** security lockset or **C-91-BB** passage set

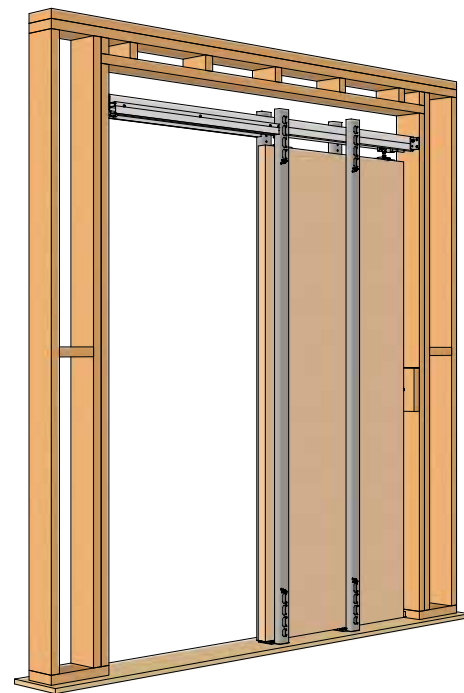

Complete Type C-W-2X6 kit illustrated.
Framing by others..

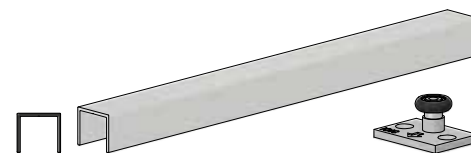

Table of Contents

Product Details & Dimensions

- 2 Section View
- 3 Plan View & Elevation View
- 4 Parts' List

Required Pre-Installation

- 6 Rough Opening Size

Installation

- 7 Installing with Door Prior to Drywall
- 13 Troubleshooting
- 14 Installing Drywall Prior to Door

Suggested Finishing & Dimensions

- 17 Section View
- 18 Plan View
- 18 Finishing Steps

Template

- 19 Top Plate Location

Overview

- 20 How It All Comes Together

Product Details & Dimensions

Section View

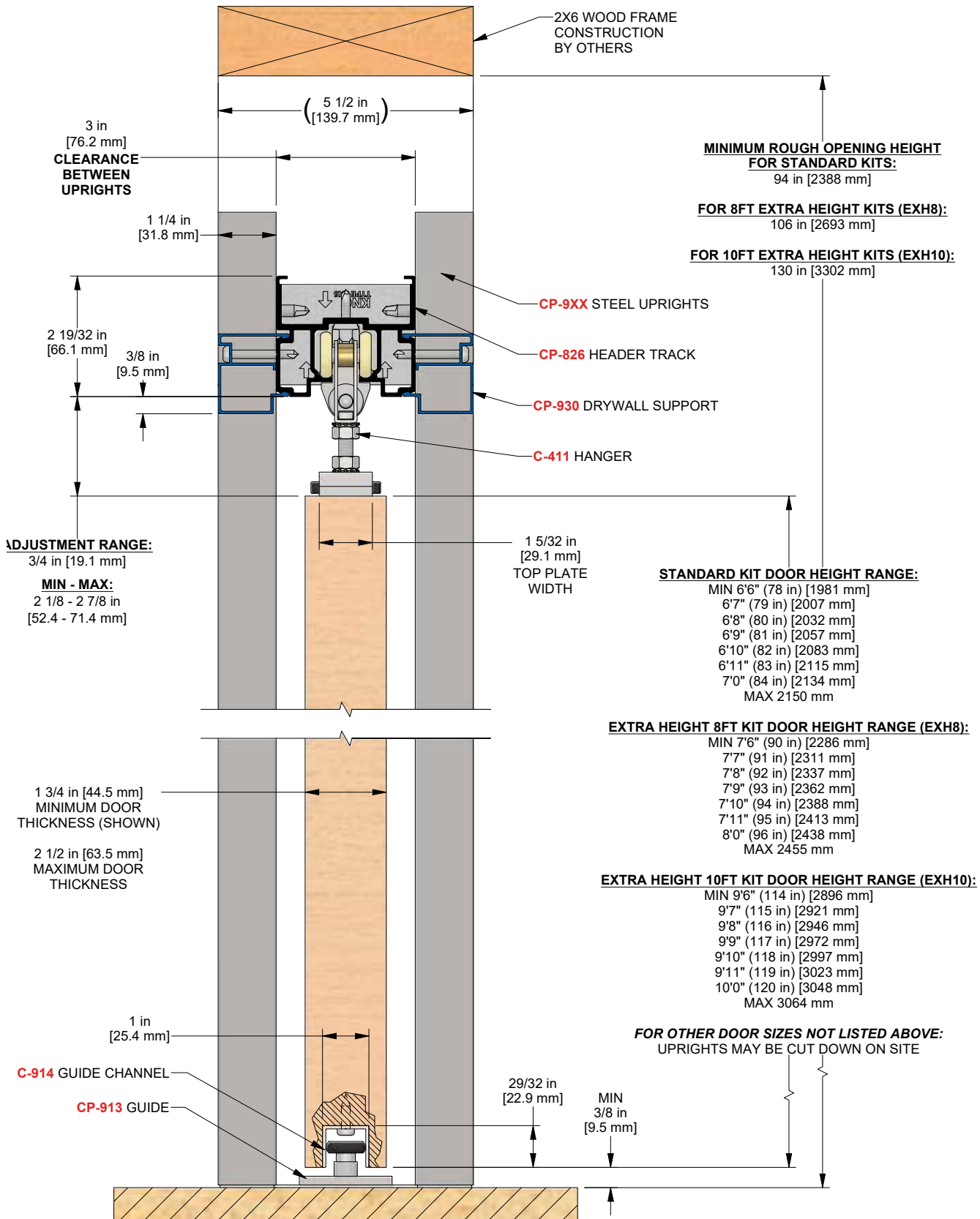

Plan View

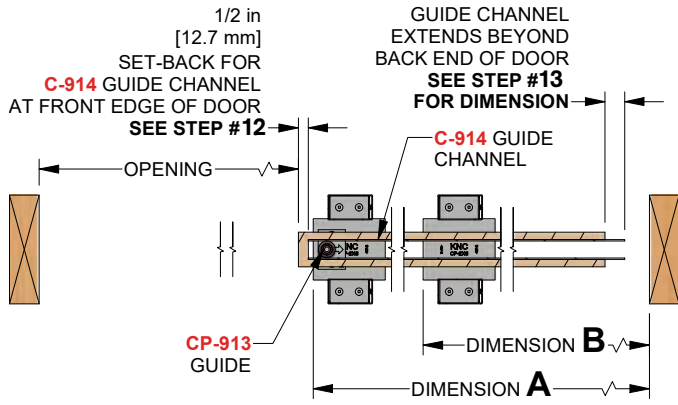

Opened position

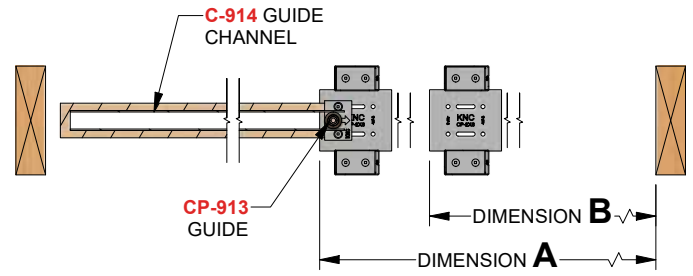

Closed position

Elevation View

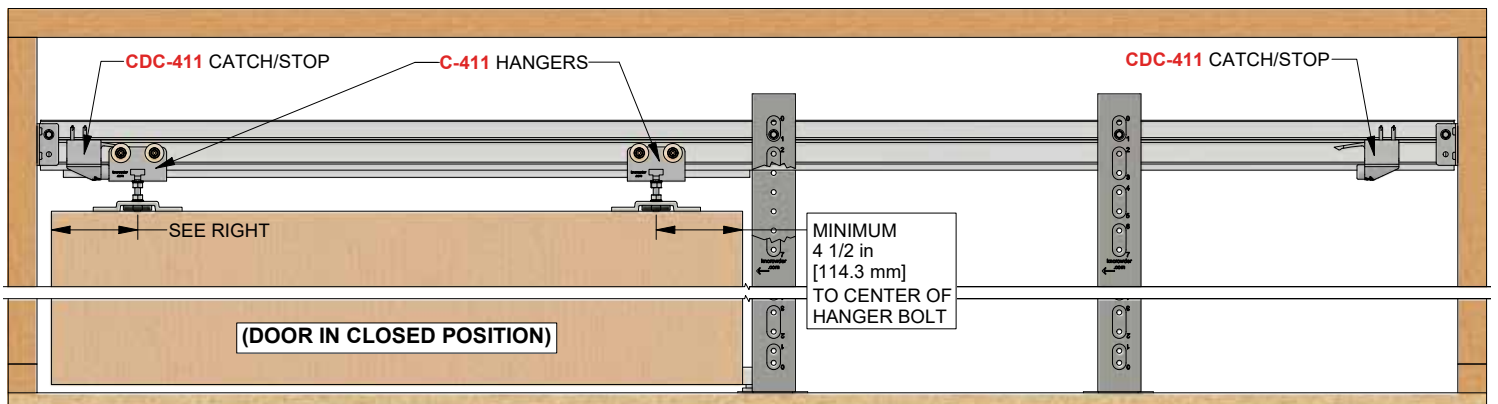
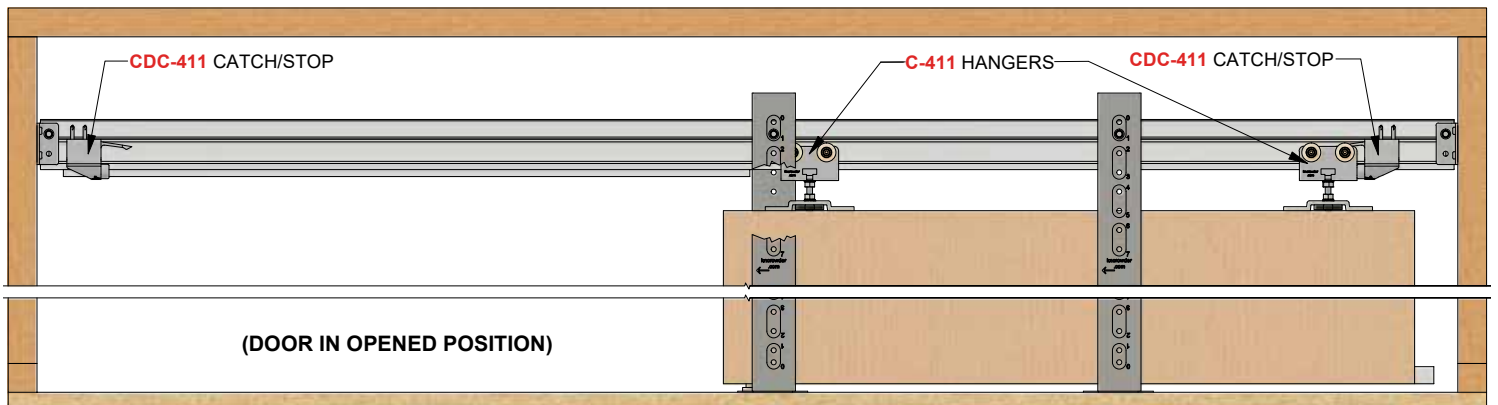

Parts' List

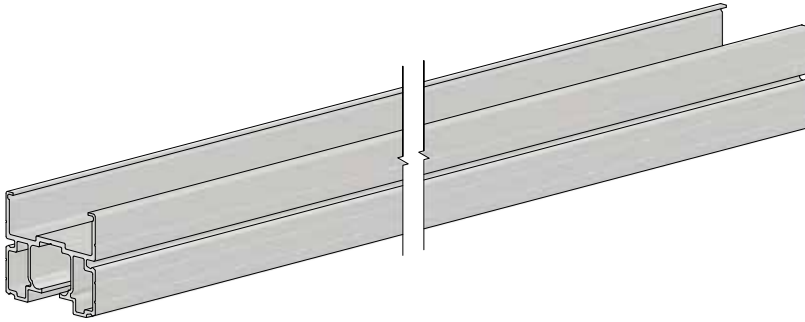

CP-826 Header Track x (length options listed below)

For Type C-W-2X6 for doors up to 36 in [914 mm] wide:

(1) piece x 73 5/8 in [1870 mm]

For Type C-W-2X6-EXW4 for doors up to 48 in [1219 mm] wide:

(1) piece x 99 5/8 in [2531 mm]

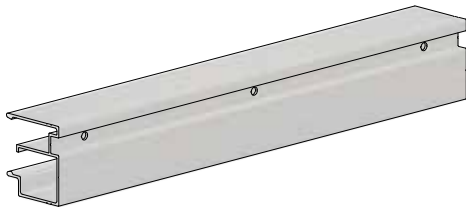
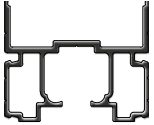

CP-930 Drywall Support x (quantity and length options listed below)

For Type C-W-2X6 for doors up to 36 in [914 mm] wide:

(2) pieces x 35 3/4 in [908 mm]

For Type C-W-2X6-EXW4 for doors up to 48 in [1219 mm] wide:

(2) pieces x 47 3/4 in [1213 mm]

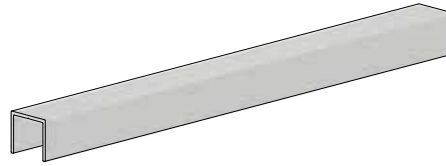

C-914 Guide Channel x length (1)

For doors up to 36 in [914 mm] wide:

(Length = door width + 1/2 in [12.7 mm], example:

36 in [914 mm] door = 36 1/2 in [927 mm] guide channel)

For doors greater than 37 in [939 mm] up to 48 in [1219 mm] wide:

(Length = door width + 2 in [50.8 mm], example:

48 in [1219 mm] door = 50 in [1270 mm] guide channel)

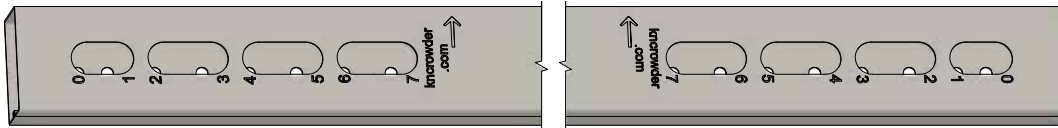

Steel uprights (quantity and part number options listed below)

For Type C-W-2X6 for doors up to 36 in [914 mm] wide x 84 in [2134 mm]/2150 mm high:

(4) CP-907 Steel Upright (90 1/2 in [2299 mm] long)

For Type C-W-2X6-EXH8 for doors up to 36 in [914 mm] wide x 96 in [2438 mm]/2455 mm high:

(4) CP-908 Steel Upright (102 1/2 [2604 mm] long)

For Type C-W-2X6-EXH10 for doors up to 36 in [914 mm] wide x 120 in [3048 mm] high:

(4) CP-910 Steel Upright (126 1/2 in [3213 mm] long)

For Type C-W-2X6-EXW4 for doors up to 48 in [1219 mm] wide x 84 in [2134 mm]/2150 mm high:

(6) CP-907 Steel Upright (90 1/2 in [2299 mm] long)

For Type C-W-2X6-EXW4H8 for doors up to 48 in [1219 mm] wide x 96 in [2438 mm]/2455 mm high:

(6) CP-908 Steel Upright (102 1/2 in [2604 mm] long)

For Type C-W-2X6-EXW4H10 for doors up to 48 in [1219 mm] wide x 120 in [3048 mm] high:

(6) CP-910 Steel Upright (126 1/2 in [3213 mm] long)

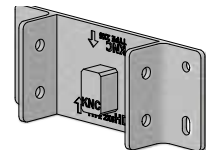
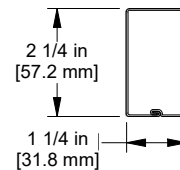

CP-HB2X6 Header Bracket (2)

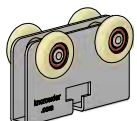

C-411 Hanger Body (2)
(c/w wheels)

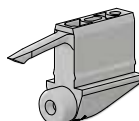

CDC-411 Catch/Stop (2)



CP-913 Pocket Guide (1)

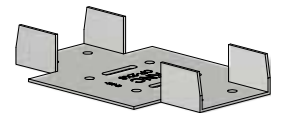

CP-2X6 Foot Bracket (2)
-EXW4 (3)

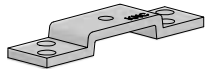

C-411 Top Plate (2)



C-411 T-Bolt (2)



C-411 Spinwheel Nut (2)



C-99 Rubber Dome Bumper (1)



3/16" Spacer Washer (8)
[FT12]



5/16"-18 K-Lock Nut (4)
[FT17]

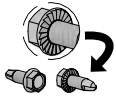

**1/4"-#14 x 3/4" Hex Tek
Screw (14)**
[FT36]



**#6 x 1" Fine Thread
Drywall Screw (60)**
[FT30]



**#10 x 3/4" Pan
Head Screw (16)**
[FT3]



**#10 x 1-1/4"
Pan Head Screw (9)**
[FT4]



#10 x 1-1/2" Flathead Screw (2)
[FT7]



**#10 x 1-1/2"
Self-Drilling Screw (8)**
[FT5]



**#10 x 1-3/4"
Flathead Screw (8)**
[FT9]



**#10 x 2-1/4"
Self-Drilling Screw (4)**
[FT6]

* Extra hardware may be included

Tools required (not supplied)

Ladder
Measuring Tape
Chalk Line
Chop Saw or Hacksaw
(for cutting aluminum)

Level
Pencil
Marker
Drill
Impact Driver

Ø1/8 in drill bit
Ø9/64 in drill bit
3/8 in Hex driver bit
#2 Robertson driver bit

#2 Robertson screw driver
1/2 in Wrench
Rubber Mallet
Air Gun or Cloth

Required Pre-Installation

Note: Read carefully - contains information which if not followed may void warranty or cause injury to users

All testing on this product has been completed with 2X6 (5 1/2 in [139.7 mm]) lumber framing studs for rough opening to provide sufficient structural support for Crowder Frame pocket door kits. (Framing details may differ based on region. Refer to your region's building codes for framing details). If any materials or support other than 2X6 lumber framing is to be used for structural support, verification by a certified structural engineer is required.

For 6 in [152.4 mm] metal stud framing, please refer to KN Crowder's 6MS Crowder Frame pocket door kits for details.

KN Crowder is not responsible for framing details. KN Crowder's warranty will not cover any issues that result from incorrect structural support/framing details.

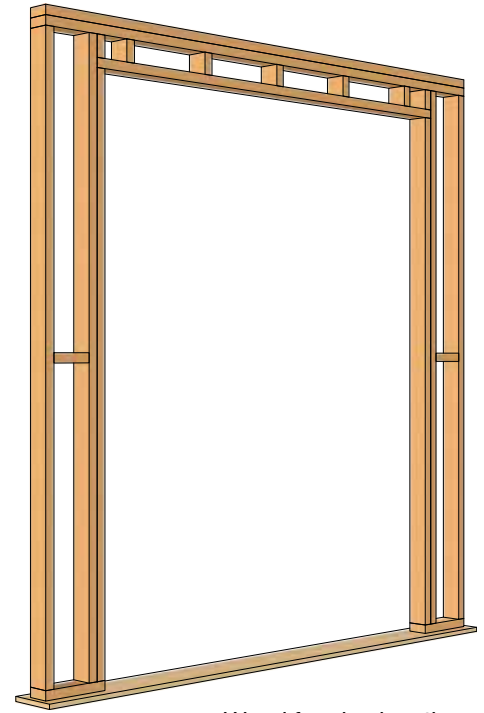

Wood framing by others

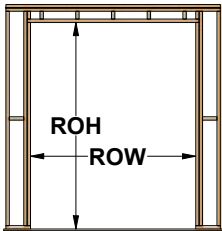

Single door opening

Rough opening height (ROH) from finished floor:

At least 94 in [2388 mm] high for doors up to 84 in (7'-0") or 2150 mm

At least 106 in [2693 mm] high for doors up to 96 in (8'-0") or 2455 mm (-EXH8 kits)

At least 130 in [3302 mm] high for doors up to 120 in (10'-0") or 3064 mm (-EXH10 kits)

Double/bi-parting door opening

Refer to CPD-2X6-Joiner Kit installation instructions [Chart CPD-2X6-A](#) for rough opening sizes.

Chart A: Rough opening size & track length

Door width			Rough opening width (ROW):		CP-826 track length required:	
18 in	(1'-6")	[457 mm]	38 in	[965 mm]	37 5/8 in	[956 mm]
20 in	(1'-8")	[508 mm]	42 in	[1067 mm]	41 5/8 in	[1057 mm]
22 in	(1'-10")	[559 mm]	46 in	[1168 mm]	45 5/8 in	[1159 mm]
24 in	(2'-0")	[610 mm]	50 in	[1270 mm]	49 5/8 in	[1261 mm]
26 in	(2'-2")	[660 mm]	54 in	[1372 mm]	53 5/8 in	[1362 mm]
28 in	(2'-4")	[711 mm]	58 in	[1473 mm]	57 5/8 in	[1464 mm]
30 in	(2'-6")	[762 mm]	62 in	[1575 mm]	61 5/8 in	[1565 mm]
32 in	(2'-8")	[813 mm]	66 in	[1676 mm]	65 5/8 in	[1667 mm]
34 in	(2'-10")	[864 mm]	70 in	[1778 mm]	69 5/8 in	[1769 mm]
36 in	(3'-0")	[914 mm]	74 in	[1880 mm]	73 5/8 in	[1870 mm]
38 in	(3'-2")	[965 mm]	80 in	[2032 mm]	79 5/8 in	[2023 mm]
40 in	(3'-4")	[1016 mm]	84 in	[2134 mm]	83 5/8 in	[2124 mm]
42 in	(3'-6")	[1067 mm]	88 in	[2235 mm]	87 5/8 in	[2226 mm]
44 in	(3'-8")	[1118 mm]	92 in	[2337 mm]	91 5/8 in	[2327 mm]
46 in	(3'-10")	[1168 mm]	96 in	[2438 mm]	95 5/8 in	[2429 mm]
48 in	(4'-0")	[1219 mm]	100 in	[2540 mm]	99 5/8 in	[2531 mm]

Track length equal to:
2x door width
+
1 5/8 in
[41.3 mm]

Track length equal to:
2x door width
+
3 5/8 in
[92.1 mm]

Installation Steps

If Installing with Door Prior to Drywall

Step #1:

On one side of rough opening, secure one CP-HB2X6 Header Bracket (orientation as shown below in detail "HB") to jamb with (4) #10 x 1-1/4" Pan Head Screws [FT4] at required height based on [Chart B](#).

Header bracket height:

Dimensions shown below for header bracket height are taken from finished floor. If finished floor will be installed after pocket door kit, add finished floor thickness to header bracket height.

Example: 84 in [2134 mm] high door with 3/4 in thick floor = 89 in [2261 mm] + 3/4 in [19.1 mm] = 89 3/4 in [2280.1 mm] new header height from sub floor (below finished floor).

Note: Foot brackets must be shimmed to level of finished floor. See step #8 for details.

Step #2:

On opposite side of opening, secure second CP-HB2X6 Header Bracket to jamb at same header bracket height from **step #1** with (2) #10 x 1-1/4" Pan Head Screws [FT4] through two oblong holes on bracket. It is recommended to only secure this bracket with two screws to allow for plumb adjustment when installing track in **step #6**.

Chart B: Header Bracket height & upright hole slot ID

Door height			Header bracket height measurement from finished floor		Type C upright hole ID
78 in	(6'-6")	[1981 mm]	83 in	[2108 mm]	7
79 in	(6'-7")	[2007 mm]	84 in	[2134 mm]	6
80 in	(6'-8")	[2032 mm]	85 in	[2159 mm]	5
81 in	(6'-9")	[2057 mm]	86 in	[2184 mm]	4
82 in	(6'-10")	[2083 mm]	87 in	[2210 mm]	3
83 in	(6'-11")	[2108 mm]	88 in	[2235 mm]	2
84 in	(7'-0")	[2134 mm]	89 in	[2261 mm]	1
84 5/8 in	(7'-0 5/8")	[2150 mm]	89 5/8 in	[2277 mm]	0
Below for -EXH8 kits					
90 in	(7'-6")	[2286 mm]	95 in	[2413 mm]	7
91 in	(7'-7")	[2311 mm]	96 in	[2438 mm]	6
92 in	(7'-8")	[2337 mm]	97 in	[2464 mm]	5
93 in	(7'-9")	[2362 mm]	98 in	[2489 mm]	4
94 in	(7'-10")	[2388 mm]	99 in	[2515 mm]	3
95 in	(7'-11")	[2413 mm]	100 in	[2540 mm]	2
96 in	(8'-0")	[2438 mm]	101 in	[2565 mm]	1
96 5/8 in	(8'-0 5/8")	[2455 mm]	101 5/8 in	[2581 mm]	0
Below for -EXH10 kits					
114 in	(9'-6")	[2896 mm]	119 in	[3023 mm]	7
115 in	(9'-7")	[2921 mm]	120 in	[3048 mm]	6
116 in	(9'-8")	[2946 mm]	121 in	[3073 mm]	5
117 in	(9'-9")	[2972 mm]	122 in	[3099 mm]	4
118 in	(9'-10")	[2997 mm]	123 in	[3124 mm]	3
119 in	(9'-11")	[3023 mm]	124 in	[3150 mm]	2
120 in	(10'-0")	[3048 mm]	125 in	[3175 mm]	1
120 5/8 in	(10'-0 5/8")	[3064 mm]	125 5/8 in	[3191 mm]	0

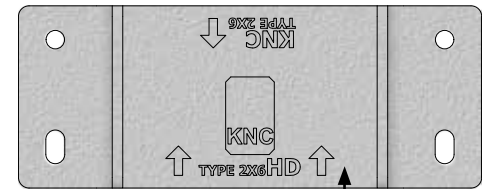

Detail "HB"

HD oriented up

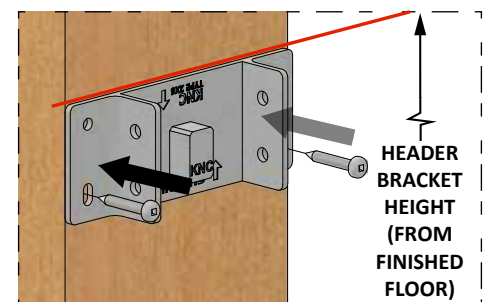
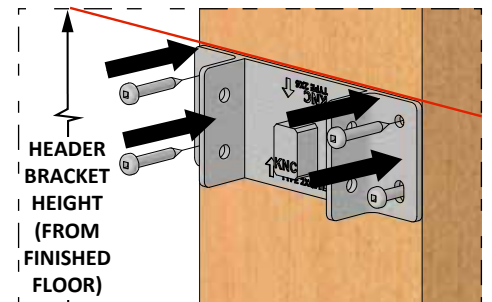

Step #3:

Cut CP-826 aluminum Header Track to correct size if required. To calculate track length:

For single door kits

For doors up to 36 in [914 mm] wide:

Length is equal to 2 x door width + 1 5/8 in [41.3 mm]. See column "CP-826 track length required" in **Chart A** for track lengths based on door widths.

For doors greater than 37 in [939 mm] up to 48 in [1219 mm] wide:

Length is equal to 2 x door width + 3 5/8 in [92.1 mm]. See column "CP-826 track length required" in **Chart A** for track lengths based on door widths.

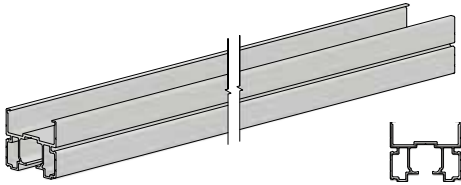

!! Attention !!
For double/bi-parting door kits, refer to **steps #CPD-2 & CPD-3** in CPD-2X6-Joiner Kit installation instructions before proceeding.

Step #4:

Slide two (2) C-411 Hanger Bodies with wheels into track from one end.

Note: Ensure "kncrowder.com" text on hanger bodies both face same side as shown below.

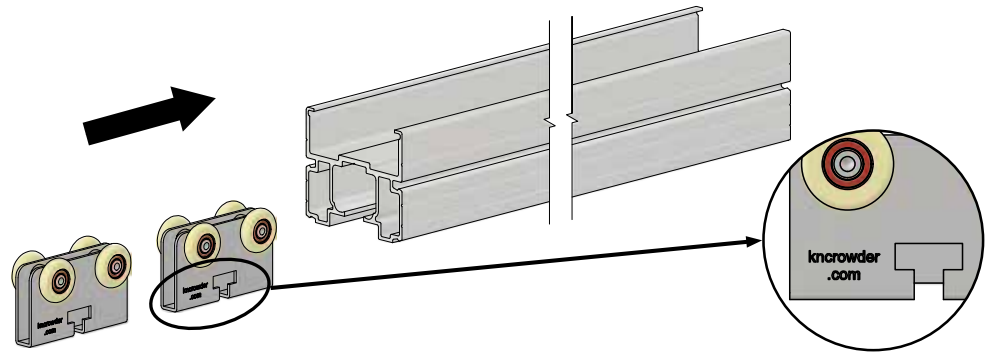

Step #5:

Place CP-826 Header Track c/w hangers onto CP-HB2X6 Header Brackets previously placed in **steps #1 - 2**.

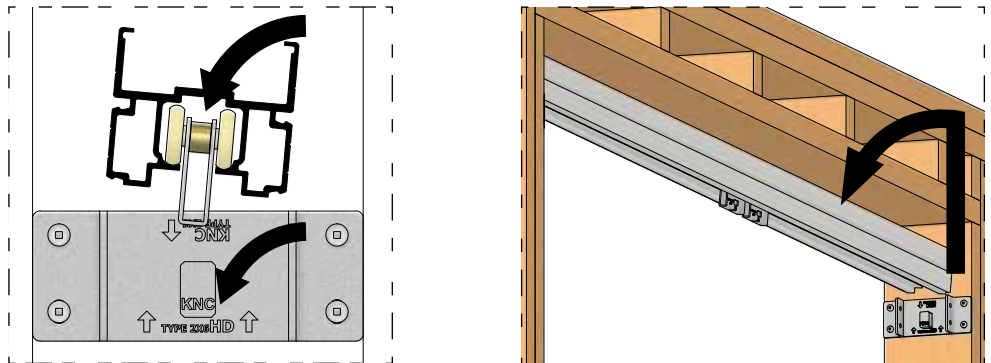

Step #6:

Check Header Track levelness and adjust loose CP-HB2X6 Header Bracket (**step #2**) until track is level. Secure CP-HB2X6 Header Bracket with (2) #10 x 1-1/4" Pan Head Screws [FT4].

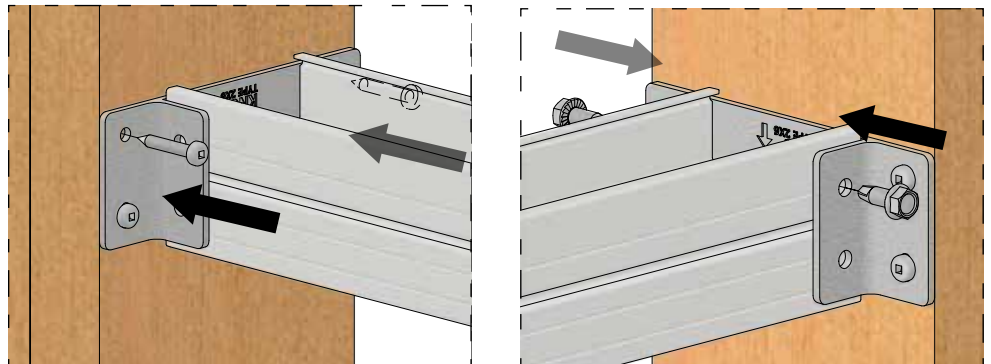

Step #7:

Secure CP-826 Header Track to CP-HB2X6 Header Brackets with (4) 1/4"-#14 x 3/4" Serrated Hex Tek Screws [FT36], two (2) per bracket.

Note: Impact driver is ideal for this step or pre-drill with Ø9/64 in [3.6 mm] drill bit if desired.

!! Attention !!
For double/bi-parting door kits, refer to **steps #CPD-5 & CPD-6** in CPD-2X6-Joiner Kit installation instructions before proceeding.

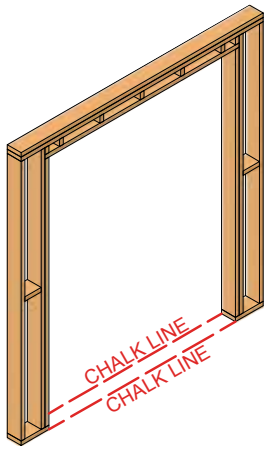

Step #8:

Use a chalk line against bottom studs of wall to mark lines of opening on both sides as shown below. Locate and secure CP-2X6 Foot Brackets (2) or (3) for extra width (EXW4) kits with (4 per bracket) #10 x 3/4" Pan Head Screws [FT3] as per foot bracket location **Chart C** below.

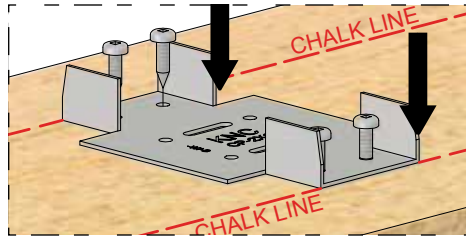

Note: Foot brackets are reversible. Foot brackets are to be mounted on finished floor. If finished floor is not installed, shim foot brackets to thickness of finished floor. Foot bracket location dimensions are based on standard set-up and will accommodate suggested finishing as shown on pages 17-18.

For double/bi-parting door kits, refer to **step #CPD-7** in CPD-2X6-Joiner Kit installation instructions before proceeding.

Chart C: Foot bracket location dimensions A, B, C

Door width			Dimension A		Dimension B		Dimension C	
18 in	(1'-6")	[457 mm]	19 1/2 in	[495 mm]	10 1/2 in	[267 mm]	----	
20 in	(1'-8")	[508 mm]	21 1/2 in	[546 mm]	10 1/2 in	[267 mm]	----	
22 in	(1'-10")	[559 mm]	23 1/2 in	[597 mm]	11 1/2 in	[292 mm]	----	
24 in	(2'-0")	[610 mm]	25 1/2 in	[648 mm]	11 1/2 in	[292 mm]	----	
26 in	(2'-2")	[660 mm]	27 1/2 in	[699 mm]	12 1/2 in	[318 mm]	----	
28 in	(2'-4")	[711 mm]	29 1/2 in	[749 mm]	13 1/2 in	[343 mm]	----	
30 in	(2'-6")	[762 mm]	31 1/2 in	[800 mm]	15 1/2 in	[394 mm]	----	
32 in	(2'-8")	[813 mm]	33 1/2 in	[851 mm]	15 1/2 in	[394 mm]	----	
34 in	(2'-10")	[864 mm]	35 1/2 in	[902 mm]	17 1/2 in	[445 mm]	----	
36 in	(3'-0")	[914 mm]	37 1/2 in	[953 mm]	19 1/2 in	[495 mm]	----	
Below apply to -EXW4 (extra width) Crowder Frame pocket door kits								
38 in	(3'-2")	[965 mm]	41 1/2 in	[1054 mm]	24 3/4 in	[629 mm]	12 in	[305 mm]
40 in	(3'-4")	[1016 mm]	43 1/2 in	[1105 mm]	26 3/4 in	[680 mm]	12 in	[305 mm]
42 in	(3'-6")	[1067 mm]	45 1/2 in	[1156 mm]	28 3/4 in	[730 mm]	12 in	[305 mm]
44 in	(3'-8")	[1118 mm]	47 1/2 in	[1207 mm]	30 3/4 in	[781 mm]	14 in	[356 mm]
46 in	(3'-10")	[1168 mm]	49 1/2 in	[1257 mm]	32 3/4 in	[832 mm]	16 in	[406 mm]
48 in	(4'-0")	[1219 mm]	51 1/2 in	[1308 mm]	34 3/4 in	[883 mm]	18 in	[457 mm]

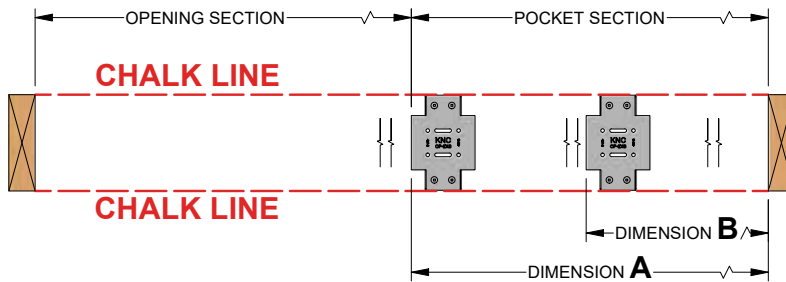

Standard Plan View
For doors 30 in [762 mm] to 36 in [914 mm] wide

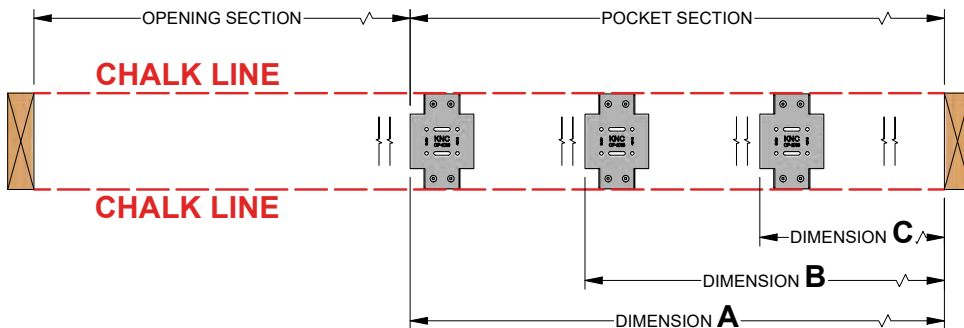

-EXW4 (extra width) Plan View
For doors 37 in [940 mm] to 48 in [1219 mm] wide

Step #9:

Place CP-913 Guide (1) on foot bracket closest to opening end and secure with (2) #10 x 1-1/2" Flathead Screws [FT7].
Note: Ensure arrow ID on CP-913 Guide is facing towards pocket as shown right.

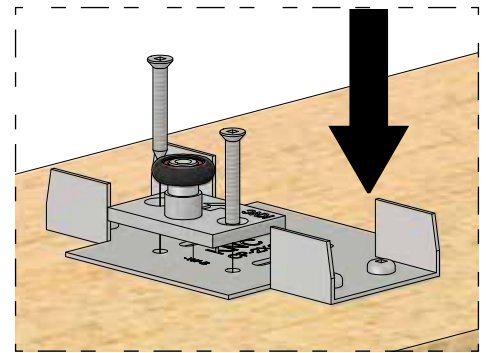
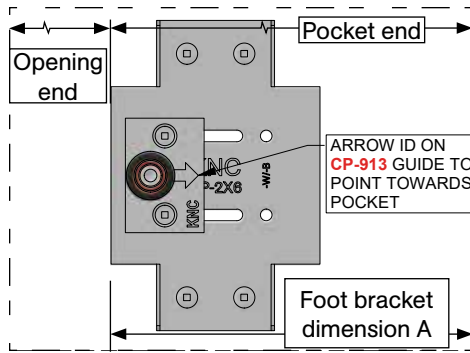

Step #10:

Position CP-9XX Steel Uprights on foot brackets with large oval clearance holes facing out and arrow ID pointing towards opening as shown below.

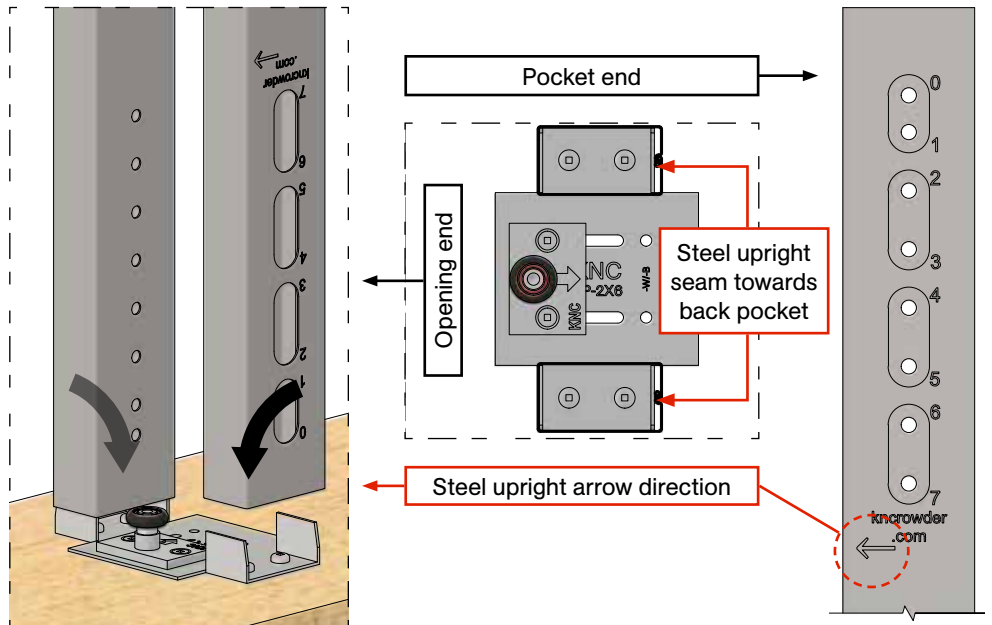

Step #11:

Plumb uprights vertically and secure to CP-826 Header Track with (1 per upright) 1/4"-#14 x 3/4" Serrated Hex Tek Screws [FT36].

Note: Screw and hole in upright should line up with first groove in CP-826 Header Track as shown below (refer to Chart B on page 7 for hole ID number to use). Impact driver is ideal for this step or pre-drill with Ø9/64 in [3.6 mm] drill bit if desired.

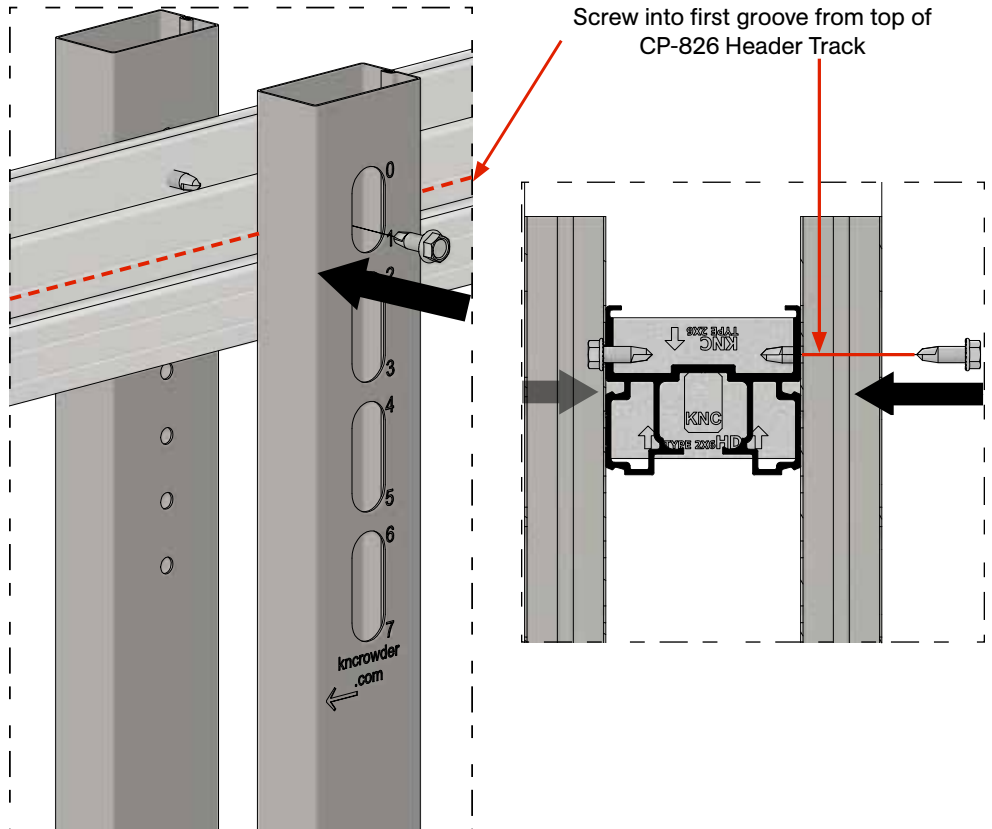

Step #12:

Prepare C-914 Guide Channel Slot in bottom of door:
1 in [25.4 mm] wide in center of door,
29/32 in [22.9 mm] deep and set back
1/2 in [12.7 mm] from front edge of door.
It is recommended to make slot as
accurate as possible for secure fit and
neat appearance.

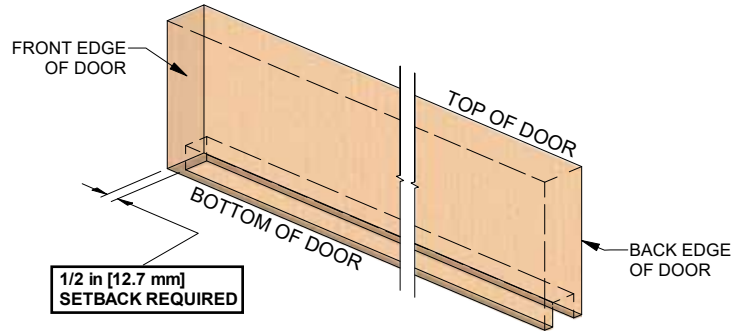
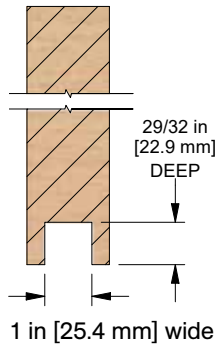

Step #13:

Cut C-914 aluminum guide channel to correct length as required.

For doors up to 36 in [914 mm] wide:

Length = door width + 1/2 in [12.7 mm], example: 36 in [914 mm]
door = 36 1/2 in [927 mm] guide channel

For doors greater than 37 in [939 mm] up to 48 in [1219 mm] wide:

Length = door width + 2 in [50.8 mm], example: 48 in [1219 mm]
door = 50 in [1270 mm] guide channel

Drill holes in C-914 Guide Channel and pre-drill holes in door. Locate
C-914 Guide Channel in slot and screw channel into place with
(4) #10 x 3/4" Pan Head Screws [FT3].

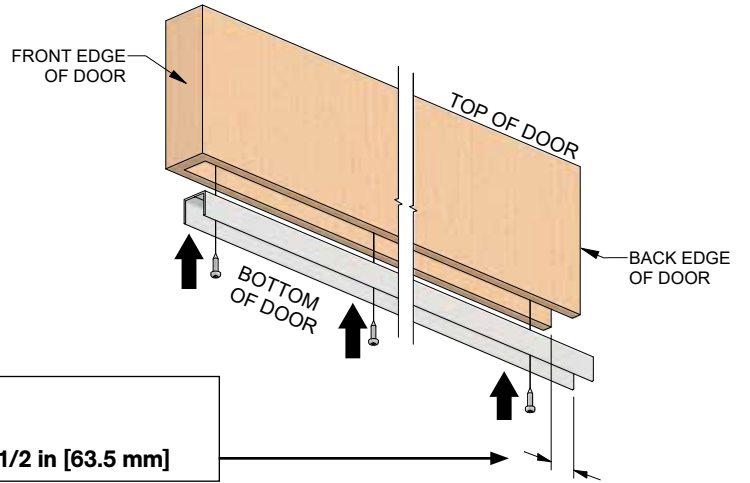

Guide channel should protrude out back edge of door by:
For doors up to 36 in [914 mm] wide = 1 in [25.4 mm]
For doors greater than 37 in [939 mm] up to 48 in [1219 mm] wide = 2 1/2 in [63.5 mm]

Step #14:

Locate center of clearance hole/top plate on top of door and drill a Ø1/2 in [12.7 mm]
clearance hole at least 2 in [50.8 mm] deep as shown right.

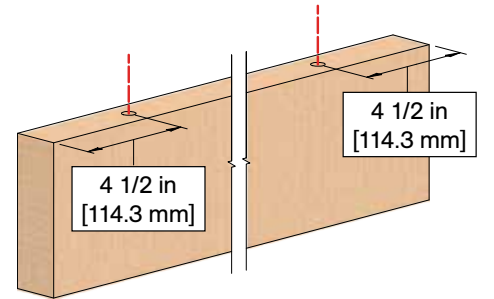

Step #15:

Assemble C-411 Top Plate assemblies as
shown right (2 assemblies required)

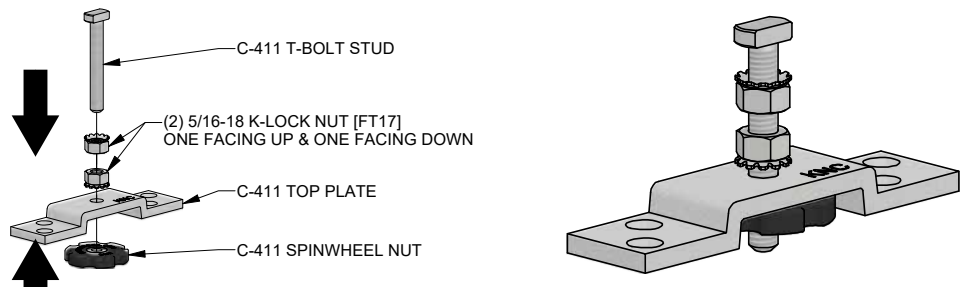

Step #16:

Place assemblies from **step #15** on top edge of door with T-Bolt placed into clearance
hole. Mark screw hole locations or use top plate template below and pre-drill
Ø1/8 in [3.2 mm] holes at least 1 1/2 in [38.1 mm] deep. Secure with (4 per hanger)
#10 x 1 3/4" Flathead Screws [FT9].

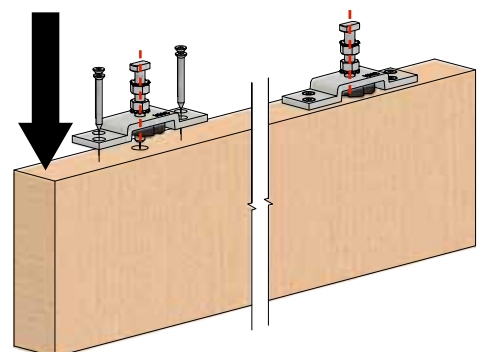

Step #17:

- A. Slide C-411 Hanger Bodies in track into opening
- B. Stand door up in opening
- C. Raise back end of door and engage T-Bolt with t-slot on back C-411 Hanger Body (closest to pocket) (arrow #1)
- D. Pivot back end of door into pocket and engage C-914 Guide Channel with CP-913 Pocket Guide
- E. Raise front end of door and engage T-Bolt with t-slot on front C-411 Hanger Body (closest to opening) (arrow #2)
- F. Adjust door height and plumb by using Spinwheel Nuts on top plate assembly
- G. Lock final height adjustment with K-Lock nuts using 1/2 in wrench

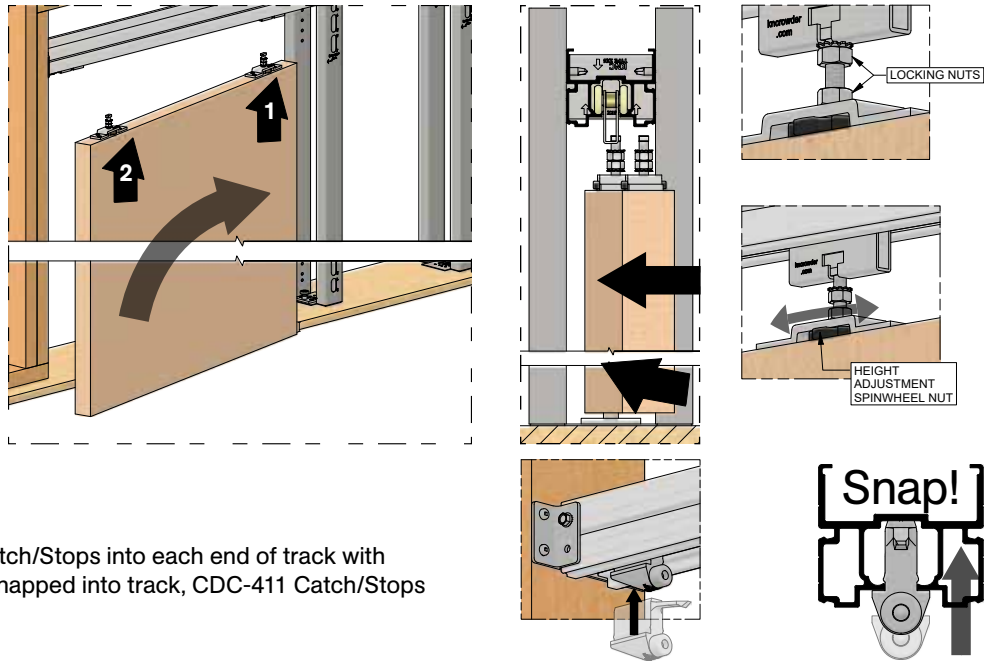

Step #18:

After door has been installed, snap CDC-411 Catch/Stops into each end of track with bumpers facing towards center of track. Once snapped into track, CDC-411 Catch/Stops should be free to slide within track.

Step #19:

Position door approximately 5-10 in [127-254 mm] away from final position at one end (shown right). Push loose CDC-411 Catch/Stop against hanger and engage it with hanger (bumper should be against hanger body).



Step #20:

With CDC-411 Catch/Stop loose, slide door to final/desired position of door.

Note: Ensure that strike and trim thickness are taken into consideration for final/desired position of door. See pages 17-18 for suggested finishing.



Step #21:

Once final position is achieved, mark outside edge of CDC-411 Catch/Stop as shown below, disengage CDC-411 Catch/Stop from hanger and slide door back. Position CDC-411 Catch/Stop at mark and secure with (1) #10 x 2-1/4" Self-Drilling Screw in oblong hole as shown right. Recheck door position and adjust CDC-411 Catch/Stop if necessary before securing CDC-411 Catch/Stop with (1) #10 x 2-1/4" Self-Drilling Screw in second hole.

Note: Remove any drill fillings from inside of track as this will affect operation of sliding door system.

Step #22:

Repeat steps #19 - 21 for opposite CDC-411 Catch/Stop.

Note: Ensure that strike and trim thickness are taken into consideration for where door will be in final position. See pages 17-18 for suggested finishing.

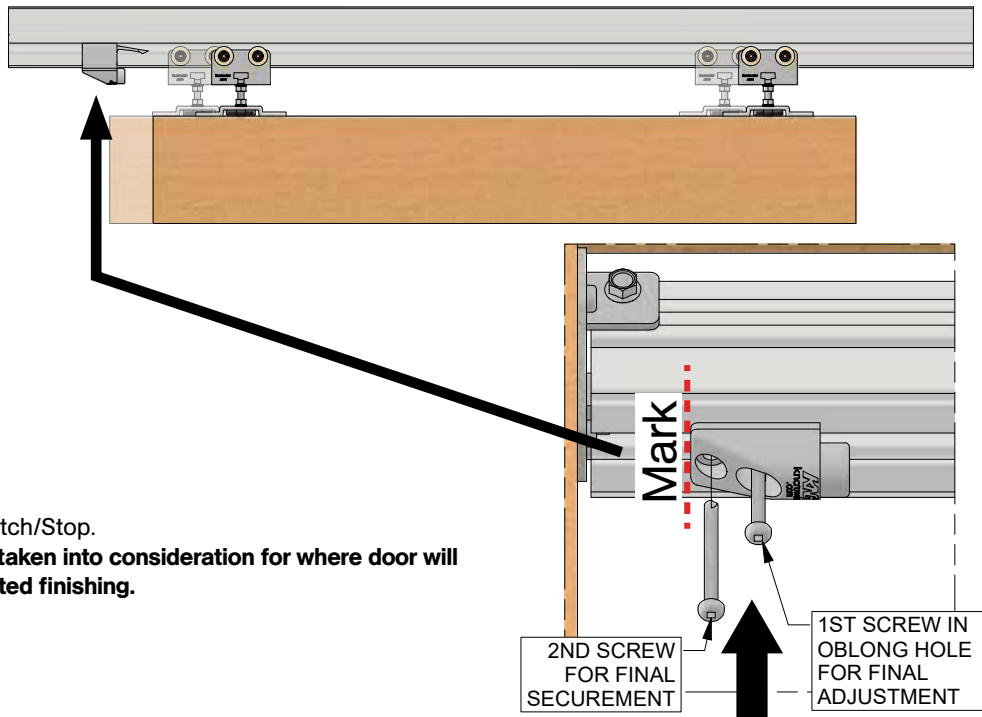

Step #23:

On pocket end framing jamb, mark halfway point from floor to under side of track. Push door into opened position (closest to pocket jamb). Measure distance from back edge of door to jamb. Install (1) C-99 Rubber Bumper with (1) #10 x 1-1/4" Pan Head Screw [FT4] and 3/16" Spacer Washers [FT12] (quantities are as required to fit in gap previously measured) to pocket jamb to act as secondary stop for door in opened position.

Note: Additional blocking may be required to fill gap.

Step #24:

If required, measure and cut CP-930 Drywall Supports to fit in opening between header bracket and first upright. If pre-punched holes are cut off, re-drill with Ø11/64 in [4.4 mm] drill bit for a total of 3 or 4 holes per piece of CP-930 Drywall Support. Two equal length pieces are required for installation. Snap CP-930 Drywall Supports onto CP-826 Header Track as shown below with step in drywall support facing down towards floor. Once snapped on, secure with (3-4 per side) #10 x 1-1/2" Self-Drilling Screws [FT32].

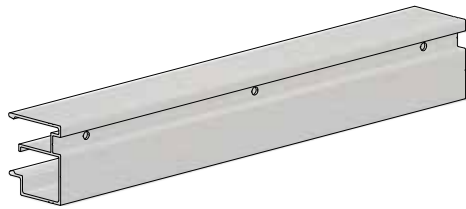
**Step #25:**

Refer to finishing suggestions, dimensions & installation steps on pages 17-18.

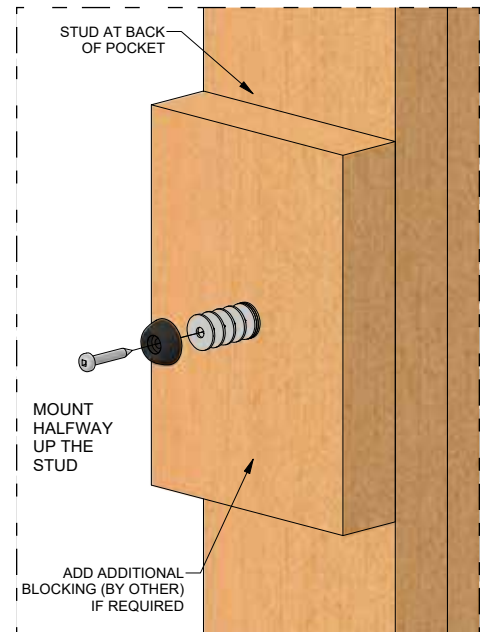
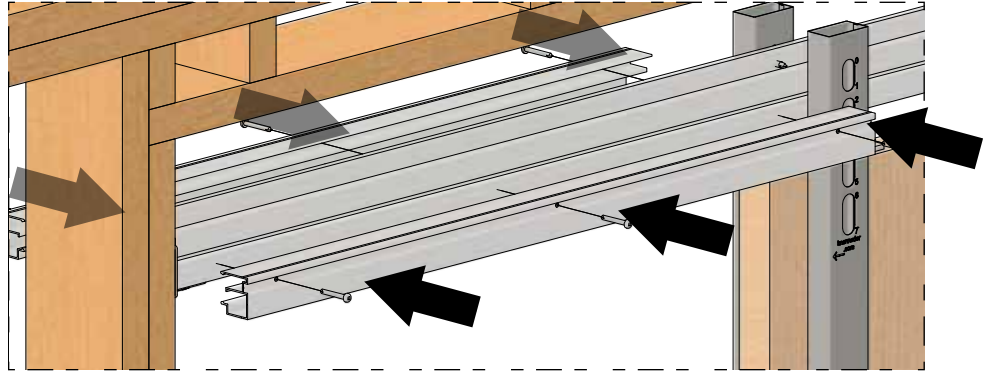
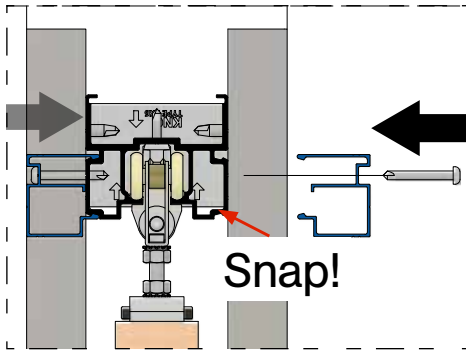
**Important note:**

Remember to clean inside of track before finishing opening. Use an air gun to blow air into track or use a cloth to wipe it. This will help eliminate any aluminum shavings or debris that may have fallen into track. If not cleaned out, shavings or debris may prevent hangers from rolling smoothly.

Troubleshooting

Issue	Solution
Chatter/noise when door is sliding	Ensure there are no aluminum shavings within track. Shavings can become embedded in nylon tires and cause noise during operation.
Door is hard to move	Ensure guide channel secured to bottom of door is not over-tightened as this could cause sides of guide channel to "pinch" guide. Remove door and check guide channel by rolling guide roller in channel to ensure smooth travel. There should be little to no resistance. Ensure door is not dragging on bottom of floor/guides and adjust height of door as required.
Door does not stay engaged with CDC-411 Catch/Stop or door slides open/closed on its own	Ensure CDC-411 Catch/Stops are installed in correct position such that hanger engages stop when door is closed. Hangers will not engage if door slams into stop. For slow closing/holding effect, see Type CC Catch 'N' Close Crowder Frame systems for application (Note, Type CC cannot be retrofitted into Type C or Type B Crowder Frames).
Door rattles	Ensure locking nuts & screws on hangers are secured and not loose.

Installation Steps

If Installing Drywall Prior to Door

Step #D1

Follow **steps #1 - 11** on pages 7-10.

Step #D2

Obtain a relatively straight scrap piece of lumber (ideally 2X6 framing lumber, not supplied by KN Crowder), and cut to size. Length should be same width as door to be installed at a later time.

For example, if door width is 36 in [914 mm], lumber length should be 36 in [914 mm].

This piece of lumber will be referred to as door template.

Step #D3:

Locate center of clearance hole/top plate on top of door and drill a $\varnothing 1/2$ in [12.7 mm] clearance hole at least 2 in [50.8 mm] deep as shown below:

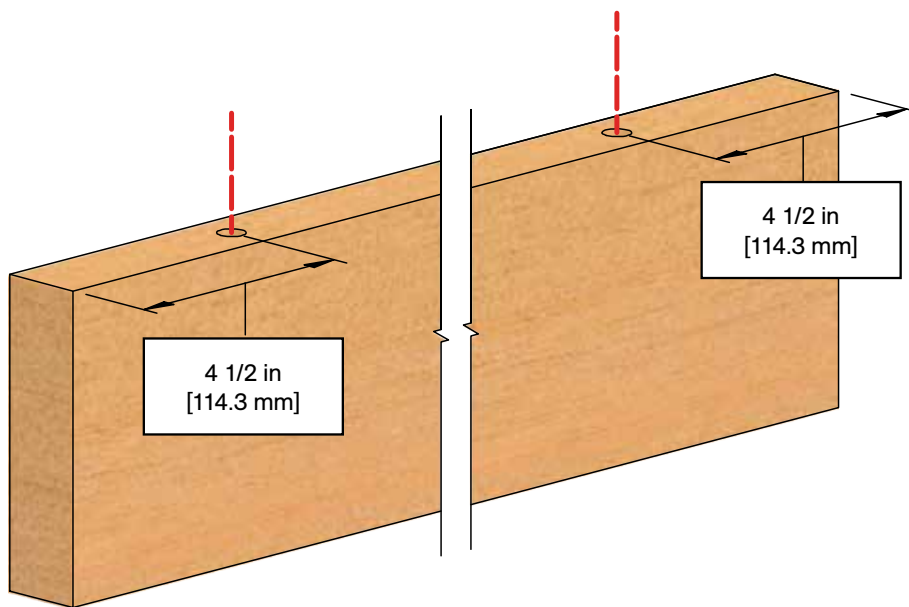

Step #D5:

Place assemblies from **step #D4** on top edge of door template with t-bolt placed into clearance hole. Mark screw hole locations or use template shown on page 19 and pre-drill $\varnothing 1/8$ in [3.2 mm] holes at least 1 1/2 in [38.1 mm] deep.

Secure with (4 per hanger) #10 x 1 3/4" Flathead Screws [FT9].

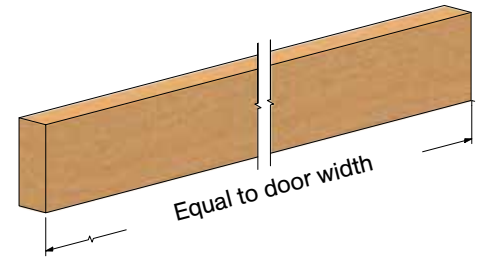
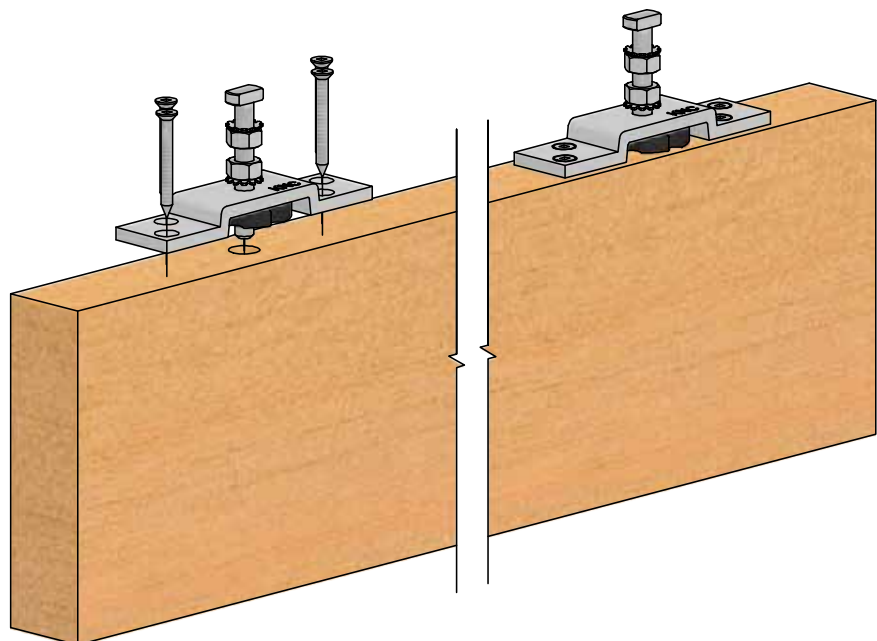

Step #D4:

Assemble C-411 top plate assemblies as shown below (2 assemblies required):

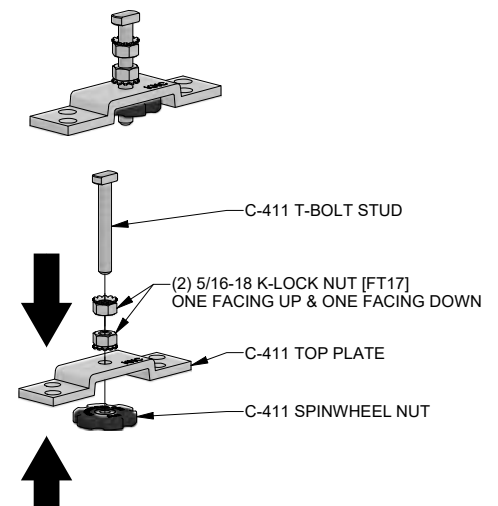

Step #D6:

- A. Slide C-411 Hanger Bodies in track into opening
- B. Position door template up in opening
- C. Raise back end of door template and engage t-bolt with t-slot on back C-411 Hanger Body (closest to pocket) (arrow #1)
- D. Pivot back end of door template into pocket
- E. Raise front end of door template and engage t-bolt with t-slot on front C-411 Hanger Body (closest to opening) (arrow #2)
- F. Adjust door template and plumb by using spinwheel nuts on top plate assembly
- G. Lock final height adjustment with k-lock nuts using 1/2 in wrench

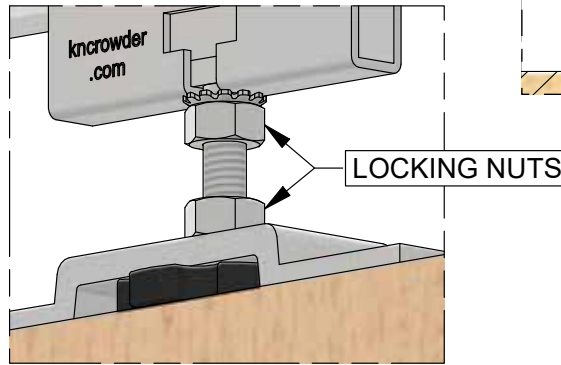
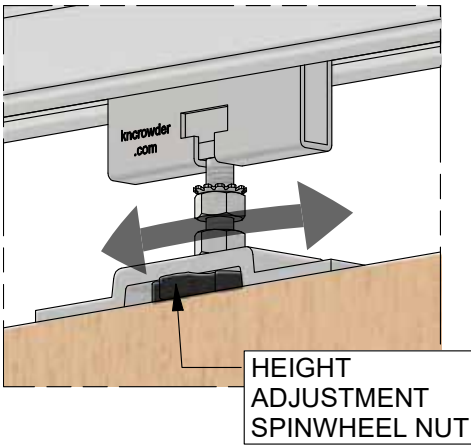
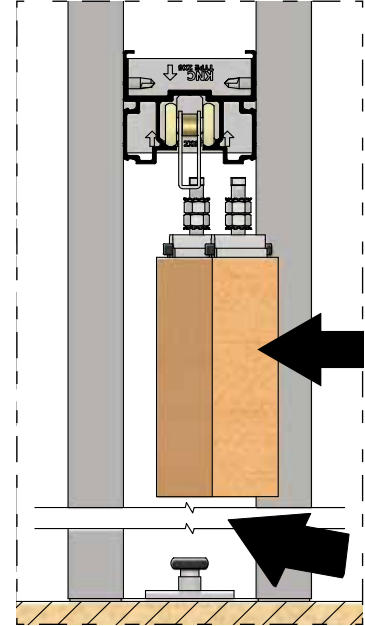
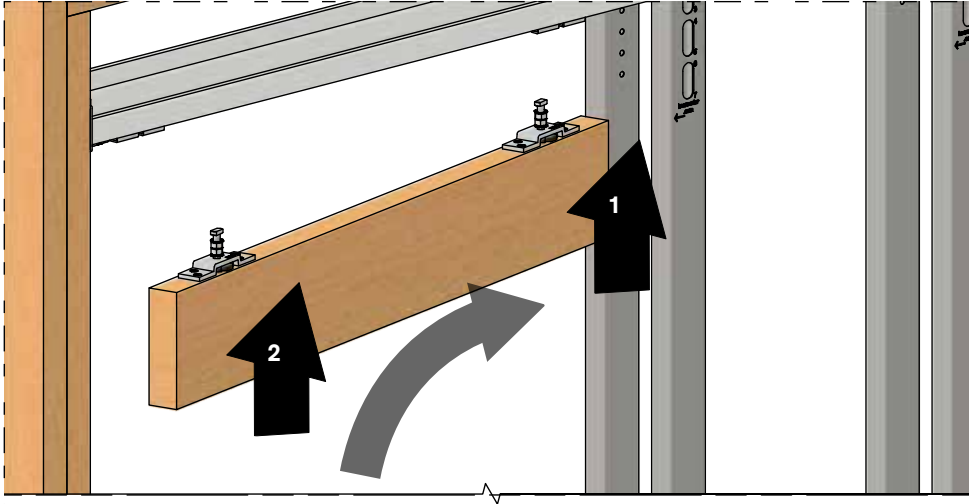

Step #D7:

Follow **steps #18 - 24** on pages 12-13.

Step #D8:

Install & finish drywall as required. Ensure drywall is cut back to strike jamb, first set of steel uprights and CP-930 Drywall Support to exposed pocket door opening. This will be the "drywall rough opening" of pocket door system.

Important drywall installation notes:

Use 1 in [25.4 mm] long drywall screws only (provided) when securing drywall to uprights & drywall supports. Longer screws will penetrate inside face of steel upright and damage door or affect door travel. Fasten drywall to bottom of steel uprights working upwards to top. It is recommended to use 8 drywall screws per upright and 4 per drywall supports.

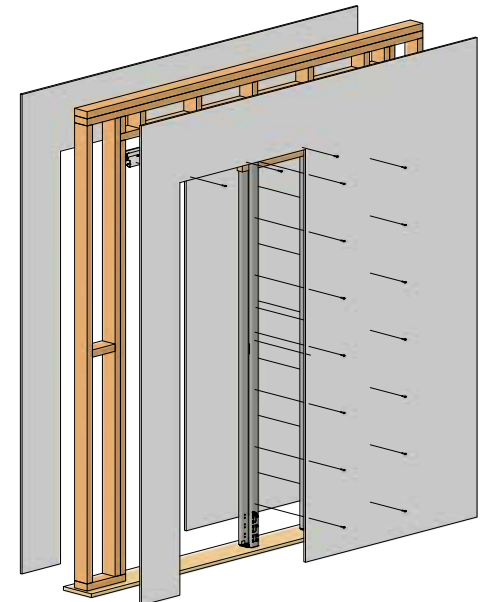

Step #D9:

Once door is on site, follow **steps #12 - 13** on page 11.

Step #D10:

Remove door template from pocket by disengaging from hangers in track (reverse **step #D6**).

Step #D11:

Remove top plate assemblies from door template and mount onto top of actual door in same position as door template per **steps #D3 - D5**.

Note: Must be mounted at same distance from edge of door as on door template.

Failure to do this will result in door not opening or closing fully in pocket.

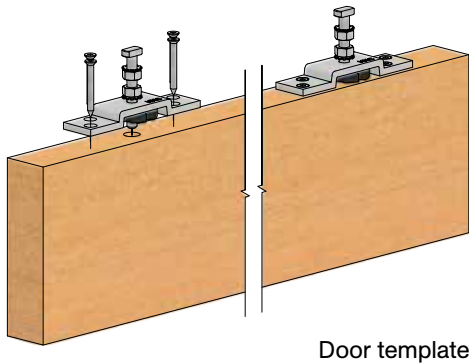
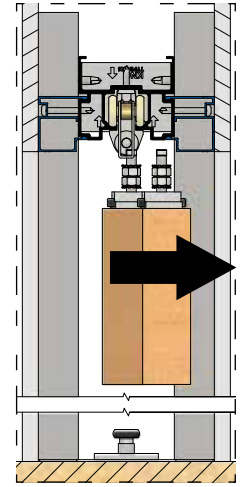
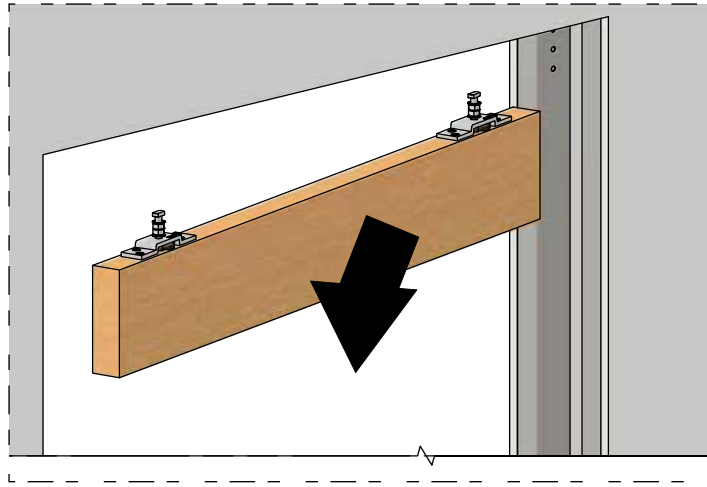

Door template

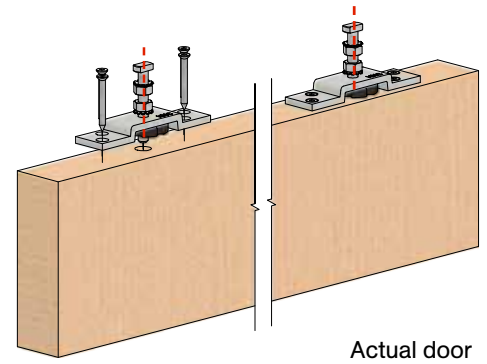
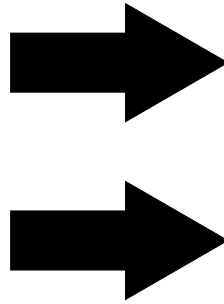

Actual door

Step #D12:

- A. Slide C-411 Hanger Bodies in track into opening
- B. Stand door up in opening
- C. Raise back end of door and engage t-bolt with t-slot on back C-411 Hanger Body (closest to pocket) (arrow #1)
- D. Pivot back end of door into pocket and engage C-914 Guide Channel with CP-913 Pocket Guide
- E. Raise front end of door and engage t-bolt with t-slot on front C-411 Hanger Body (closest to opening) (arrow #2)
- F. Adjust door height and plumb by using spinwheel nuts on top plate assembly
- G. Lock final height adjustment with k-lock nuts using 1/2 in wrench

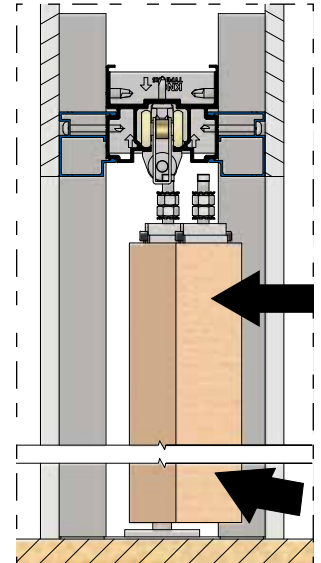
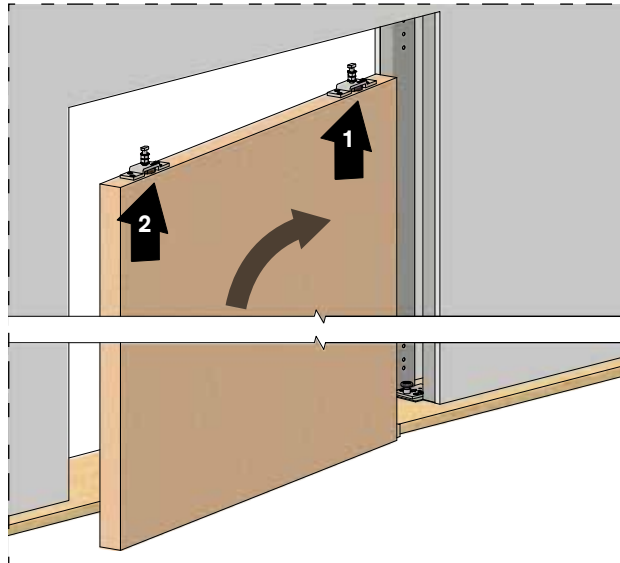

Step #D13:

Finish project with finishing requirements such as trim, door jambs, etc (all by others). Refer to finishing suggestions, dimensions & installation steps on pages 17-18.

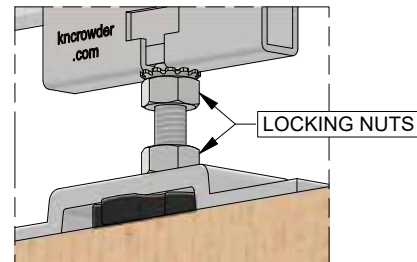
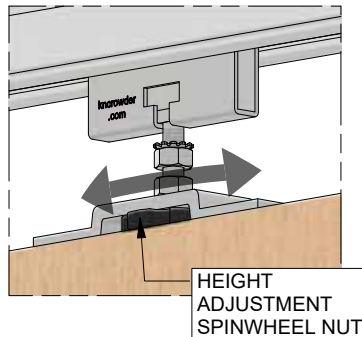

Suggested Finishing & Dimensions

Complete Type C-W-2X6 kit illustrated with framing, drywall, & suggested finishing by others.

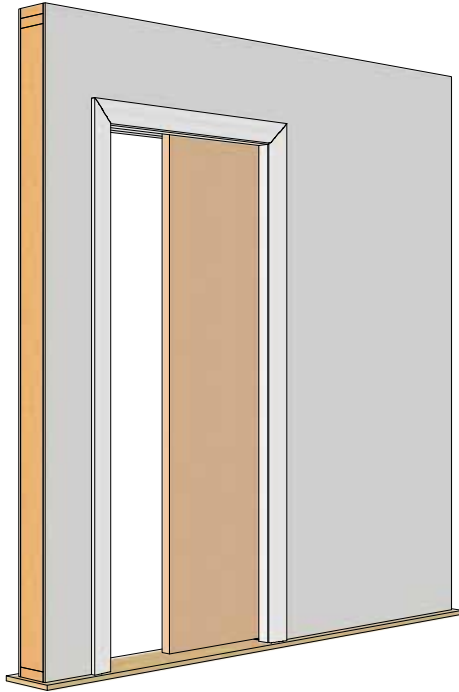

To illustrate complete installation process, suggested trim details and dimensions are shown. Site trim details and dimensions must be verified by installer and may require adjustment of dimensions that follow.

KN Crowder is not responsible for any finishing details.

Suggested details are based on a 36 in [914 mm] wide x 84 in [2134 mm] high door using **Type C-W-2X6** Crowder Frame pocket door kit.

Note:
For double door kits using CPD-2X6-Joiner Kit, use this section detail for reference.

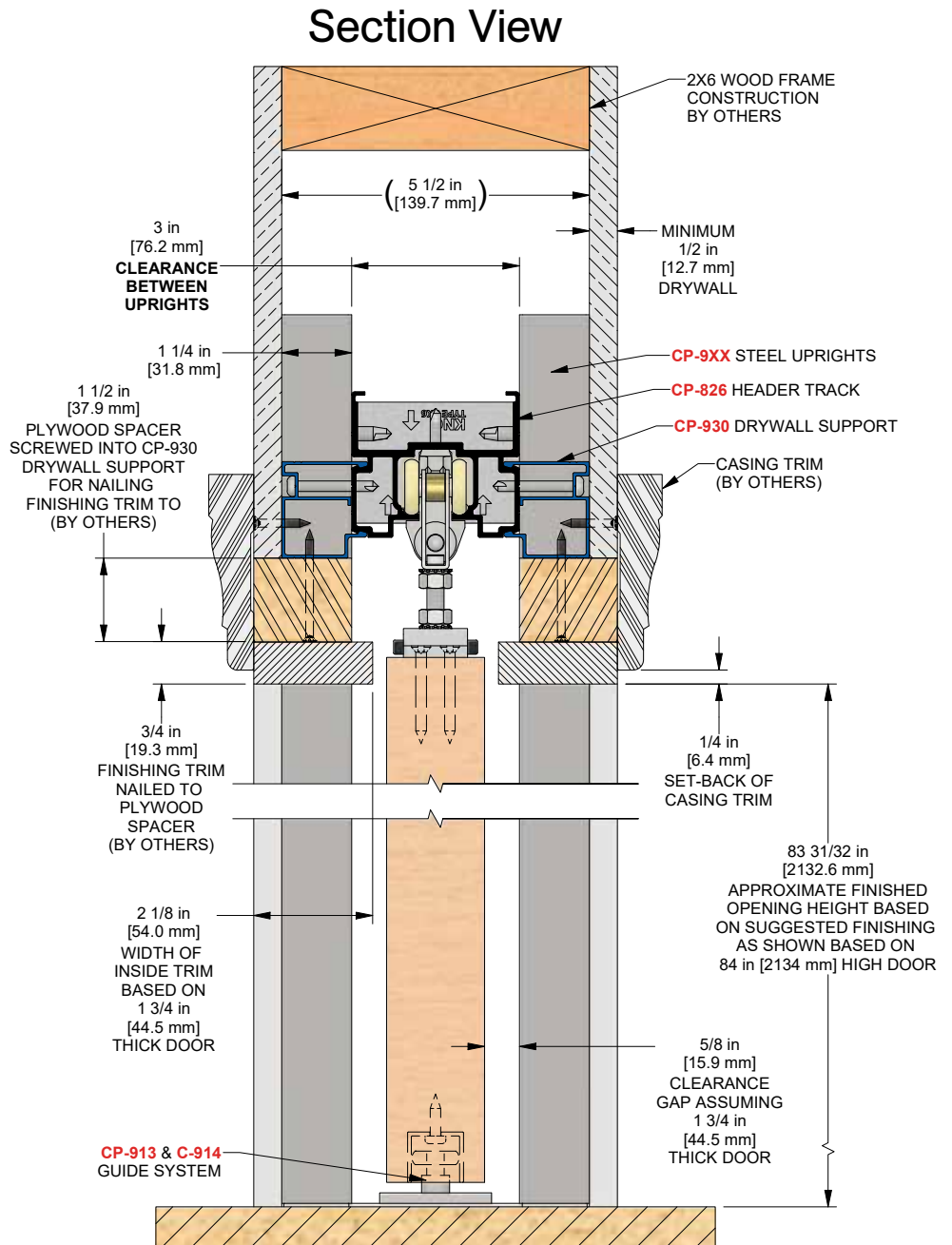

Plan View

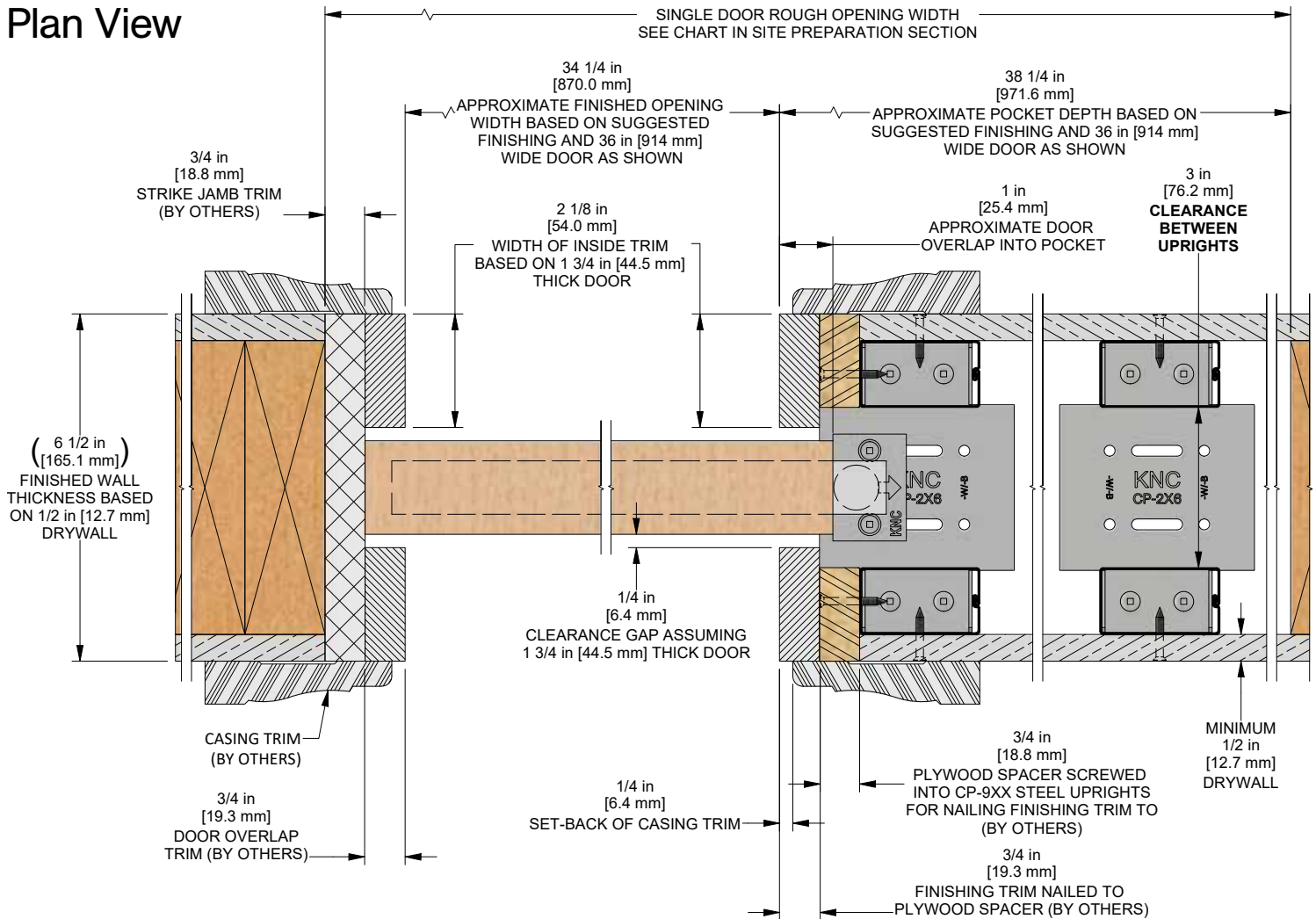

Finishing Steps

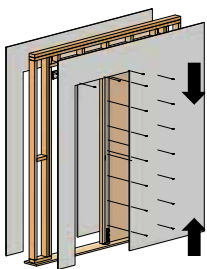

Step #F1:

Use 1 in [25.4 mm] long drywall screws only (provided) when securing drywall to uprights & drywall supports. Fasten drywall alternating between top & bottom of steel uprights. It is recommended to use 8 drywall screws per upright and 4 per drywall supports.

Note: longer screws may penetrate inside face of steel upright and damage door or affect door travel.

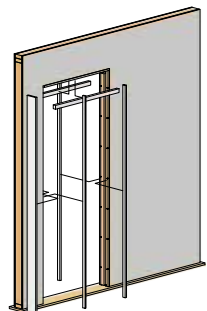

Step #F3:

Install jamb finishing board on strike side and finishing pocket trim at header and pocket side of opening (by others).

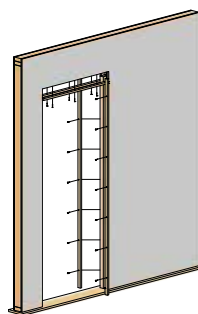

Step #F2:

Install plywood/wood spacer (by others) to steel uprights & drywall support using screws (by others).

Note: installing plywood/wood spacers will allow finishing trim to be nailed to spacers with a brad nailer for smaller holes to fill after installation.

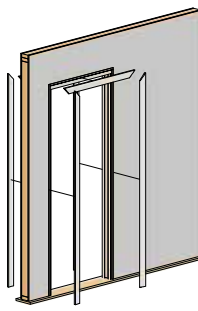

Step #F4:

Install finishing casing around opening (by others).

Note: it is recommended to make one side of trim "easily" removable for future access for maintenance purposes.

CLEARANCE HOLE LOCATION TEMPLATE

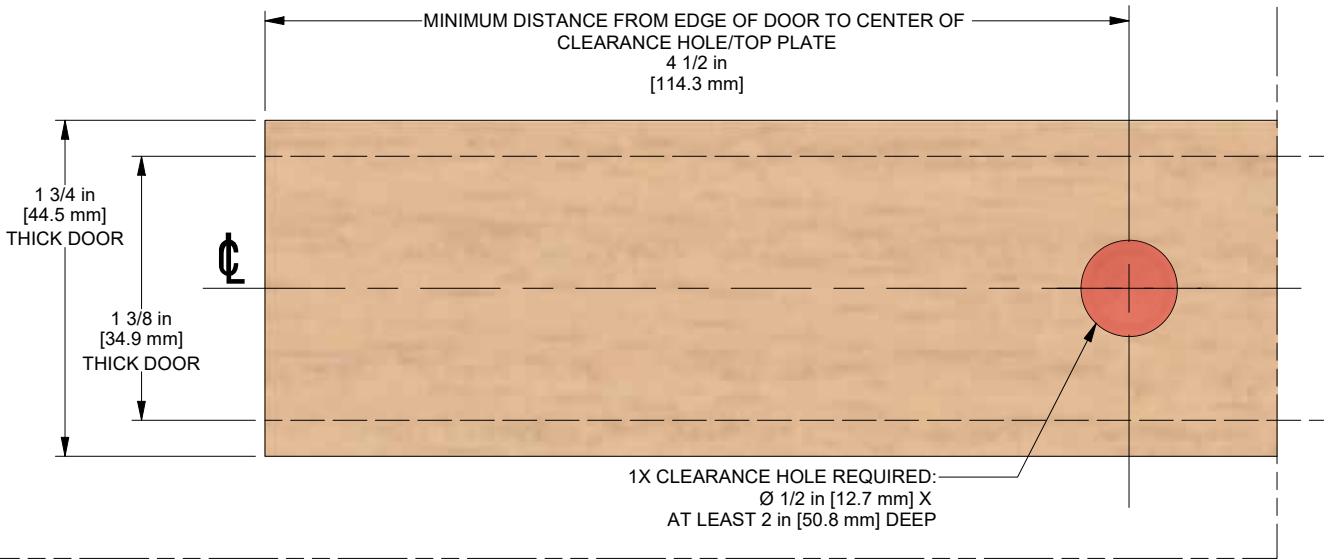

Top Plate Template

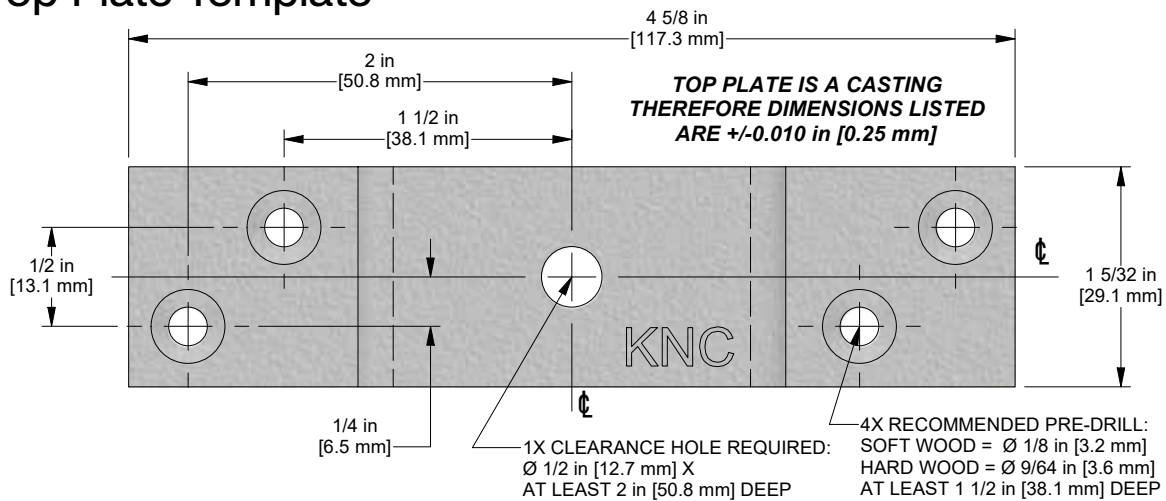

How It All Comes Together

